

# Building Science

Students investigate the science behind keeping building occupants healthy and comfortable and our buildings energy efficient. Hands-on activities and simulations help students to evaluate building performance and their own home energy use.

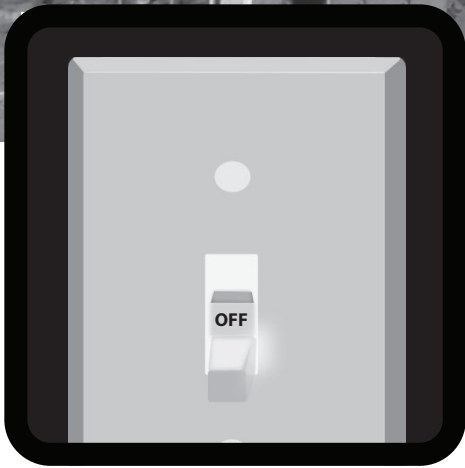

**Grade Level:**

**Int** Intermediate

**Subject Areas:**



Science



Social Studies



Language Arts



Technology



National Energy Education Development Project



# NEED Mission Statement

The mission of The NEED Project is to promote an energy conscious and educated society by creating effective networks of students, educators, business, government and community leaders to design and deliver objective, multi-sided energy education programs.

## Permission to Copy

NEED curriculum is available for reproduction by classroom teachers only. NEED curriculum may only be reproduced for use outside the classroom setting when express written permission is obtained in advance from The NEED Project. Permission for use can be obtained by contacting [info@need.org](mailto:info@need.org).

## Teacher Advisory Board

In support of NEED, the national Teacher Advisory Board (TAB) is dedicated to developing and promoting standards-based energy curriculum and training.

## Energy Data Used in NEED Materials

NEED believes in providing teachers and students with the most recently reported, available, and accurate energy data. Most statistics and data contained within this guide are derived from the U.S. Energy Information Administration. Data is compiled and updated annually where available. Where annual updates are not available, the most current, complete data year available at the time of updates is accessed and printed in NEED materials. To further research energy data, visit the EIA website at [www.eia.gov](http://www.eia.gov).

# Teacher Advisory Board

**Shelly Baumann**  
Rockford, MI

**Barbara Lazar**  
Albuquerque, NM

**Constance Beatty**  
Kankakee, IL

**Robert Lazar**  
Albuquerque, NM

**James M. Brown**  
Saratoga Springs, NY

**Leslie Lively**  
Porters Falls, WV

**Amy Constant - Schott**  
Raleigh, NC

**Jennifer Mitchell - Winterbottom**  
Pottstown, PA

**Nina Corley**  
Galveston, TX

**Mollie Mukhamedov**  
Port St. Lucie, FL

**Regina Donour**  
Whitesburg, KY

**Don Pruett Jr.**  
Sumner, WA

**Linda Fonner**  
New Martinsville, WV

**Joanne Spaziano**  
Cranston, RI

**Samantha Forbes**  
Vienna, VA

**Tom Spencer**  
Chesapeake, VA

**Michelle Garlick**  
Long Grove, IL

**Jennifer Trochez MacLean**  
Los Angeles, CA

**Erin Gockel**  
Farmington, NY

**Jen Varrella**  
Fort Collins, CO

**Robert Griegoliet**  
Naperville, IL

**Wayne Yonkelowitz**  
Fayetteville, WV

**Bob Hodash**  
Bakersfield, CA

**DaNel Hogan**  
Tucson, AZ

**Greg Holman**  
Paradise, CA

**Matthew Inman**  
Spokane, WA



1.800.875.5029  
[www.NEED.org](http://www.NEED.org)  
© 2016



Printed on Recycled Paper



# Building Science

**The NEED Project gratefully acknowledges the work of the following individuals in the creation and development of *Building Science*:**

Joseph Miuccio, HVAC/R Adult Education Instructor at Onondaga, Cortland, Madison BOCES and former Lead Instructor for the Center for Energy Efficiency and Building Science (CEEBS) at Hudson Valley Community College

Dale Sherman, President, Energywright

## Building Science Kit

- 2 Infrared (IR) thermometers
- 2 Stackolators
- 50 Unscented incense sticks
- 1 Mini-blower door
- 2 Insul-boxes®
- 2 Kill A Watt® monitors
- 2 Digital humidity/temperature pens
- 2 Probe thermometers

## Table of Contents

▪ Standards Correlation Information	4
▪ Materials	5
▪ Teacher Guide	6
▪ Student Informational Text	33
▪ What Does a Building Analyst Do?	46
▪ House as a System Organizers	48
▪ Conduction	52
▪ Radiation	53
▪ Home Airflow Simulation	55
▪ Energy Systems and Sources	57
▪ Windows Investigation	58
▪ Investigating Windows and Air Infiltration at Home	59
▪ Investigating Home Insulation and Infiltration	60
▪ Recommended R-Value Map	61
▪ Temperature Investigation	62
▪ Investigating Thermostats at Home	63
▪ Reading EnergyGuide Labels	64
▪ Comparing EnergyGuide Labels	65
▪ Comparing Appliances	66
▪ Appliances and EnergyGuide Labels	67
▪ Kill A Watt® Monitor Instructions	68
▪ Kill A Watt® Investigation 1	69
▪ Kill A Watt® Investigation 2	70
▪ Facts of Light	71
▪ Comparing Light Bulbs	72
▪ Home Light Audit	73
▪ Home Energy Use Survey	74
▪ House Design Project	75
▪ Evaluation Form	79

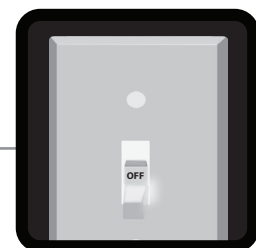



# Standards Correlation Information

www.NEED.org/curriculumcorrelations

## Next Generation Science Standards

- This guide effectively supports many Next Generation Science Standards. This material can satisfy performance expectations, science and engineering practices, disciplinary core ideas, and cross cutting concepts within your required curriculum. For more details on these correlations, please visit NEED's curriculum correlations website.

## Common Core State Standards

- This guide has been correlated to the Common Core State Standards in both language arts and mathematics. These correlations are broken down by grade level and guide title, and can be downloaded as a spreadsheet from the NEED curriculum correlations website.

## Individual State Science Standards

- This guide has been correlated to each state's individual science standards. These correlations are broken down by grade level and guide title, and can be downloaded as a spreadsheet from the NEED website.

The screenshot shows the NEED website interface. At the top left is the NEED logo (National Energy Education Development Project). To the right are social media icons for Facebook, Twitter, Instagram, Pinterest, LinkedIn, and YouTube. Below these is a search bar with the text "Search this site:". A navigation menu includes links for "About NEED", "Educators", "Students", "Partners", "Youth Awards", "Contact", and "Shop". On the left side, there is a vertical menu with dropdown arrows for "Curriculum Resources", "Professional Development", "Evaluation", "Supplemental Materials", "Curriculum Correlations", and "Distinguished Service and Bob Thompson Awards". The main content area shows the breadcrumb path "> Educators > Curriculum Correlations" followed by the heading "Curriculum Correlations". Below the heading is a paragraph: "NEED has correlated their materials to the Disciplinary Core Ideas of the Next Generation Science Standards. NEED has also correlated all of their materials to The Common Core State Standards for English/Language Arts and Mathematics. All materials are also correlated to each state's individual science standards. Most files are in Excel format. NEED recommends downloading the file to your computer for use. Save resources, don't print!". A list of links follows: "Navigating the NGSS? We have What You NEED!", "NEED alignment to the Next Generation Science Standards", "Common Core State Standards for English and Language Arts", and "Common Core Standards for Mathematics". At the bottom of the list are state names: Alabama, Alaska, Arizona, Arkansas, and California. On the left side of the screenshot, there is a green calendar icon and a text box that says "NEED is adding new energy workshops all the time. Want to".

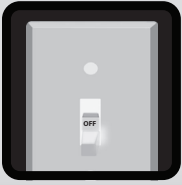

# Building Science Materials

ACTIVITY	MATERIALS IN KIT	ADDITIONAL MATERIALS NEEDED
<i>Thermal Energy Transfer via Conduction</i>	<ul style="list-style-type: none"> <li>▪ Insul-boxes®</li> <li>▪ Infrared (IR) thermometers</li> </ul>	<ul style="list-style-type: none"> <li>▪ Standard heating pad</li> <li>▪ Aluminum foil</li> <li>▪ Extra insulation materials samples (optional)</li> </ul>
<i>Thermal Energy Transfer via Radiation</i>	<ul style="list-style-type: none"> <li>▪ IR thermometers</li> </ul>	
<i>Home Airflow Simulation</i>	<ul style="list-style-type: none"> <li>▪ Stackolators</li> <li>▪ Incense sticks</li> </ul>	<ul style="list-style-type: none"> <li>▪ Rolls of tape</li> </ul>
<i>Building Performance Diagnostics</i>	<ul style="list-style-type: none"> <li>▪ Kill A Watt® monitors</li> <li>▪ Digital humidity/temperature pens</li> </ul>	<ul style="list-style-type: none"> <li>▪ Pencils</li> <li>▪ Tape</li> <li>▪ Tissue paper</li> </ul>
<i>Energy Web</i>		<ul style="list-style-type: none"> <li>▪ Name badges (optional)</li> <li>▪ Ball of yarn</li> </ul>
<i>High Performance House Design Project</i>	<ul style="list-style-type: none"> <li>▪ Probe thermometer</li> <li>▪ Stackolator bases</li> <li>▪ Mini-blower door</li> </ul>	<ul style="list-style-type: none"> <li>▪ Clear packing tape</li> <li>▪ 10 Pieces heavy transparency film</li> <li>▪ Rope caulk</li> <li>▪ Rulers</li> <li>▪ Scissors (or x-acto knives)</li> <li>▪ Construction supplies</li> </ul>



# Teacher Guide

## Grade Level

- Intermediate, grades 6-8

## Time

- 5-10 class sessions

## Additional Resources

This guide is an excellent extension to any efficiency and conservation unit. If your students are in need of additional efficiency and conservation activities, background information, or would like to learn more about the school as a system, download these titles from [www.NEED.org](http://www.NEED.org):

- Monitoring and Mentoring*
- Plug Loads*
- Saving Energy at Home and School*
- Energy Conservation Contract*

## Background

Residential and commercial buildings consume a lot of energy. The people inside of the buildings are an influential factor in how energy is consumed, but the building design and components can also play a major role. In this module, students will learn how the parts of a building work together as a system to provide a safe, healthy, comfortable, and energy efficient environment for its residents.

Through a series of hands-on investigations, students will explore how heat transfers into and out of a system. They will also learn how to conduct a home energy audit and will use what they learn to design an energy efficient home.

## Preparation

- Familiarize yourself with the information and activities in the guide.
- Make copies of the pages you are going to use for each student, including two copies of the survey as a pre- and post- activity.
- Conduct or set-up the activities in advance so that you are familiar with the materials.

## Activity 1: Introduction to House as a System

### Objective

- Students will be able to describe the house as a system with interconnected parts, listing how each part of the system relates to or affects others.

### Time

- 45 minutes

### Materials

- Student Informational Text*, pages 33-47
- House as a System Organizers*, pages 48-51

### Procedure

- Assign students to read the *Student Informational Text*. Give them the *House as a System Organizers* so they can track new learning and important information.

**OPTIONAL:** This reading can be conducted as a jigsaw. Assign students different sections of the backgrounder to read. Students should take notes on their section using their organizers and present the information to their classmates. The class may fill in the remainder of the organizers as they hear/see presentations. A suggested breakdown of the text might include:

- House as a System
  - How Our Homes Use Energy
  - Using and Saving Energy in the House System
  - HVAC, Water Heating, and Lighting
  - Appliance and Electrical Devices, High Performance/Green Buildings, Occupants
  - What Does a Building Analyst Do?
- Introduce the *House Design Project* so your students can be thinking about, designing, and working on the project throughout the unit. See page 75 for more information.

## Activity 2: Thermal Energy Transfer via Conduction

---

### Objectives

- Students will be able to describe conduction as the process where thermal energy is transferred directly from one particle to another when the particles are in direct contact with each other.
- Students will be able to explain that insulation works to slow down heat transfer via conduction.
- Students will be able to compare the relative effectiveness of different insulating materials.

### Time

- 45 minutes

### Materials

- Insul-box®
- Sheet of aluminum foil same size as Insul-box®
- Standard heating pad
- Extra optional insulating materials (e.g., cellulose, foam board, fiberglass, foam)
- Infrared (IR) thermometer
- *Conduction* worksheet, page 52
- *Recommended R-Value Map*, page 61

### Preparation

- The activity description below assumes that the Insul-box® is used as part of a whole-class activity. It can also be run as a station in combination with Activity 3 and Activity 4. In this case, the first group records initial temperatures and turns on the heating pad. Each subsequent group records a temperature while they are at the station. One copy of the worksheet is used for recording temperatures and is left at the station for each group to use.
- Fill each cavity of the Insul-box® with one of the types of insulation. One cavity should remain empty. Make sure to keep track of the color cavity that contains each type of insulation.

### Procedure

1. To introduce conduction and insulation, ask students to put one of their hands palm down on their desks. Ask students to raise their hands if the desk feels cool or cold. Then ask students to raise their hands if the desk feels warm. Explain that if the desk felt cool they are transferring heat to the desk and if it felt warm the desk is transferring heat into their hands. Explain that this type of heat transfer is called conduction. This heat transfer occurs between objects (particles) that are in direct contact with one another. As an alternative or extension, students can pair up and touch their palms together instead of touching the desk. Ask students to indicate whether their partner's hand feels cool or warm.
2. Share with students that this type of heat transfer is critical in determining how much energy a home uses for heating and cooling. Describe that a furnace must work to replace the thermal energy that is lost, and that an air conditioning system must work to remove the thermal energy gained. Then explain to students that insulation is installed in walls, attics, and other locations. It works to slow down heat transfer by forcing heat or thermal energy to move through dead air spaces within the insulating material. Materials that are effective at slowing down the heat transfer are called insulators and materials that transfer heat effectively are called conductors. Ask students to brainstorm examples of conductors (e.g., a metal pot or pipe, or a glass window) and examples of insulators (e.g., a down coat, a pot holder, or carpeting).
3. Next, ask students to touch various surfaces in the room. Be sure to include metal surfaces. Ask students to share which surfaces felt cooler or warmer to the touch. Using the IR thermometer, measure the temperatures of these surfaces. You will likely find that these surfaces are close to the same temperature. Ask students why one surface would feel colder than another even though it is nearly the same temperature. After discussing, clarify to students that surfaces which felt cooler are conducting heat away from the hand more quickly because their molecules are closer together. This decreases the amount of trapped air spaces that slow down heat transfer.

**CONTINUED ON PAGE 8**

**CONTINUED FROM PAGE 7**

4. Discuss insulation and how it is used in a home to slow down heat transfer due to conduction. Describe various insulating materials and pass around samples of cellulose, fiberglass, and foam.
5. Introduce the activity by asking students, “What material do you think is the best insulation?” Listen to student answers and promote discussion. At this point, do not provide any answers or discuss how different materials work better in different situations. Allow for student discovery during the activity.
6. Explain to students that they will be working with an Insul-box® to experiment with different types of insulation and determine their relative insulating effectiveness. Show students the device so they can see that it has four cavities and is heated by a heating pad. Explain that they will not be able to see what is in each cavity, but that each cavity will either be empty, or filled with cellulose, fiberglass, or foam. Students will need to develop a hypothesis about what is in each cavity based on the temperature changes they observe.
7. Refer students to their worksheet’s data table and explain how they will observe temperatures at 10-minute intervals. Once the readings are complete, they will calculate the total temperature change in each cavity.
8. Remind students that each cavity’s initial temperature *should* be room temperature, but they might be slightly different. Unless the temperatures are drastically different this is okay. Since we are calculating the total temperature change, it does not matter what the initial temperature reading is.
9. Show students the IR thermometer and explain that when the button is pressed, the device measures the surface temperature of any object at which it is directed. Explain that the thermometer has a laser that is used to focus the sensor on the surface being measured. Looking into the laser can be harmful to the eyes, so the thermometer should never be aimed at someone above the neck.
10. Direct a student to aim the IR thermometer at the target for each chamber and direct all other students to record the temperatures on their worksheets.
11. Then, turn on the heating pad to the highest setting. Tell students to take readings at 10-minute intervals. Between readings, if they haven’t done so already, they should also read the Building Envelope section on insulation in the informational text (page 38). Let students know that they will be given questions to answer based on the reading. Direct students to the *Recommended R-Value Map*, letting them know that they will need this resource to answer some of the questions.
12. Once all the temperature readings are complete, tell students to make predictions about what type of insulation is in each cavity. They should try to come to an agreement within their groups and then record the prediction(s) on the data gathering forms.
13. Begin by asking one student what cavity had the greatest temperature change, and ask them to predict what the insulating material is. Ask the student what information led him/her to his/her conclusion. Students should record their predictions on their worksheets and/or on the board. Establish that the uninsulated cavity should have had the greatest rise, demonstrating that any insulation is better than no insulation.
14. Reveal the type of insulation in each of the cavities.
15. Discuss the results and whether student predictions were correct. Ask students to share the reasoning behind their predictions.
16. Wrap up the discussion with the questions, “What do you think is the best insulation? Why might one use or not use a particular type of insulation?” Students should see that while some materials have a greater ability to slow down conductive heat transfer than others, some insulation types will work better than others in any given situation. For instance:
  - While foam insulates the best, it is the most expensive. So, in an attic, it might be impractical to install foam on the floor. Fiberglass and cellulose are more cost-effective choices.
  - In an empty (uninsulated) wall cavity, cellulose is an effective choice. Due to its properties, sprayed foam cannot be installed in an enclosed space such as this.



## Activity 3: Thermal Energy Transfer via Radiation

### Objectives

- Students will be able to define radiant heat transfer.
- Students will be able to describe how heat transfer via radiation can affect their comfort at home.

### Time

- 45 minutes

### Materials

- IR thermometers
- *Radiation* worksheet, pages 53-54

### Preparation

- This activity can be run as a station in combination with Activity 2 and Activity 4. Set up stations for these activities if done in conjunction.

### Procedure

1. Introduce radiant heat transfer by telling students that they will be using an infrared (IR) thermometer to help them understand how thermal energy transfers via radiation.
2. Ask students to pair up and instruct them each to hold up one hand, palm out, a couple inches away from their partner's palm. The one with the colder hands should feel the heat or thermal energy from their partner's hand. As an alternative, students can be directed to place their hands close to a heat source that is not hot enough to burn them such as:
  - A radiator or other heating appliance that is less than 120°F
  - A window on a hot day
  - A container with hot water inside

**NOTE:** There should not be a fan associated with the heat source since that introduces convective heat transfer, a concept covered separately.
3. Explain that the heat or thermal energy they feel is due to radiant heat transfer. As another example, describe how when standing by a campfire you feel hotter on the side facing the fire, but not on the side facing away. This is because heat is transferred by radiation only to surfaces that are within direct sight. Explain that the heat does not need a gas, liquid, or solid in order to transfer in this way. Radiant heat transfer occurs across the vacuum of space from the sun to Earth. Have students write a definition of thermal radiation in their own words.
4. Show students the IR thermometer and explain that when the button is pressed, the device measures the surface temperature of any object at which it is directed.
5. Refer students to their worksheets. Go over the instructions and ensure student understanding. Explain that the thermometer has a laser that is used to focus the sensor on the surface being measured. Looking into the laser can be harmful to the eyes, so the thermometer should never be aimed at someone above the neck.
6. Using the data table on the worksheet, work with the class on two examples in the room. Have students choose two items and predict the temperature range in which they would fall. Check their predictions with the IR thermometer. Then, on the board, draw a box to represent a map of the room. Mark the locations of the two items on the map, then draw an arrow from one to the other indicating the direction of heat transfer via radiation.
7. Monitor student progress as they work through the activity.
8. After they have completed the activity, review their results, and discuss findings as a class.

CONTINUED ON PAGE 10

## CONTINUED FROM PAGE 9

9. Discuss how radiant heat transfer can be a major factor in how comfortable you are in a room. Explain that a room that is 70 degrees Fahrenheit on a cold, winter's day often feels colder than a 70 degrees Fahrenheit room on a hot, summer day. This is largely due to the colder temperature of the wall, which causes a higher rate of radiant heat transfer from you to the wall.
10. Based on their results, have students write or give examples of how radiant heat transfer can affect the heating (or cooling) of their home.
11. Have students write their definition of radiant heat transfer.
12. To wrap up, discuss student responses to the conclusion at the end of the activity.

## Activity 4: Home Airflow Simulation (Convection)

### Objectives

- Students will be able to define convection as the transfer of thermal energy by the movement of the heated parts of a liquid or gas.
- Students will be able to explain why the top and bottom of a house are the most effective locations to air seal.

### Time

- 45 minutes

### Materials

- Stackolators
- *Home Airflow Simulation* worksheet, pages 55-56
- Incense stick or other smoke generator
- Roll of tape

### Note

Smoke is seen best against a dark background. Since the Stackolators give off their own light, the activity will work better with the lights off and shades drawn.

### Preparation

- This activity can be run as a station in combination with Activity 2 and Activity 3. Set up stations for these activities if done in conjunction.

### Procedure

1. Ask students if they've ever noticed air movement in their homes, or at school, even if the windows and doors were closed. Allow students to discuss where air movement was noticed and what allowed air into the house/school.
2. Introduce students to the Stackolator. Show its component parts and explain that they will be using this to model air movement in the home.
3. Tell students to imagine that the Stackolator is their home. Point to the bottom two holes and explain that this area represents the basement. Ask students to brainstorm locations where air could enter or leave the basement. Then point to the upper three holes and explain that these represent the first and second stories of their homes. Ask where air could enter or leave the first and second stories of their homes.
4. Removing the cap, explain that this opening represents openings between the house and the attic—explain that they need to imagine a roof above. Ask students to share their experiences of being in an attic to ensure understanding. Discuss openings to the attic including hatches, recessed lights, and wall tops.
5. Break students into groups of three or four and distribute materials.
6. Demonstrate the use of the incense or smoke generator. Give examples of where it might be used (around windows and doors, electrical outlets, ductwork). If using an incense stick, demonstrate the correct positioning of the stick for testing. The smoking tip should be held up against the bottom lip of the hole being tested.

7. Hand out the worksheets and go over the instructions. Point out the different scenarios, making sure that students understand the procedure. Use or project a diagram to demonstrate how to indicate closed holes and direction of air flow when testing an open hole. If ANY smoke is drawn into a hole, it should be recorded as a hole that is drawing in, even if some smoke stays outside the tube.
8. Monitor each group's progress. Make sure that their procedures reflect an understanding of the experiment's intent. Redirect as necessary and stop the action to give instruction to the whole class as needed.
9. When the experiment is complete, instruct students to answer the conclusion questions.
10. Discuss their findings as a class. Students should see air entering the Stackolator through the lower holes and exiting through the upper holes. The force of the air entering and exiting increases towards the top and bottom. In the final structured scenario, students should notice that the air does not really enter or leave the Stackolator. This demonstrates that sealing the top and bottom of the home will actually decrease air flow into and out of openings in the body of the home. Convection is the force driving this dynamic—warmer, less dense air rises in the Stackolator, drawing in the cooler air behind it through the lower holes. Building analysts call this dynamic the stack effect, since the home is behaving like a smoke stack, which is designed to specifically take advantage of this principle.

### Extension

- Discuss how a building analyst ensures that a house isn't sealed too tightly. Students can research blower door testing online or show students a video clip of this process.

### Home Airflow Simulation Answer Key

1. In general, where did you observe air entering the tube?  
*Students should indicate that they observed air entering through the lower holes (or basement).*
2. In general, where did you observe air exiting the tube?  
*Students should indicate that they observed air exiting the tube through the upper holes (first and second floors or attic).*
3. At what locations did sealing make the greatest impact on reducing air flow through the Stackolator (refer to diagrams 1-4 on your worksheet)? Why do you think this is?  
*The top and the bottom. Warm air rises in the Stackolator due to its lower density. As the air rises and exits at the top, it pulls cooler air in behind it through openings at the bottom.*
4. As a result of this experiment, in what area of a house do you think air sealing would have the greatest impact on energy use? Why?  
*The attic is the most important. The basement is important to seal as well.*  
*Sealing the attic stops the warm air from escaping, which will minimize the air that can enter low in the house. Sealing the basement limits the air that can be drawn in behind the warm, rising air. A properly sealed home will reduce the amount of work heating and cooling systems need to perform to maintain a comfortable temperature.*

## Activity 5: Building Performance Diagnostics

### Background

This activity is split into four parts. It is designed so that four or more student groups can become experts on a certain type of building performance diagnostics, share their findings and important information with the class, and teach the class how to collect data at home. At the close of the lesson, students should be able to take diagnostics of all the areas in their homes to inform the creation of a conservation contract drafted with their families. If desired, however, these activities can be split into their individual parts and completed as a class.

### Objective

▪ Students will be able to describe how to use simple diagnostic tools to assess the performance of the school building, and their homes.

### Time

▪ Two to three 45 minute class sessions, with homework and time in between for data collection at home

### Materials

- Kill A Watt® monitors
- Digital humidity/temperature pens
- *Energy Conservation Contract* for each student, available from [www.NEED.org](http://www.NEED.org)
- *Energy Systems and Sources* worksheet, page 57
- *Home Energy Use Survey*, page 74
- Pencils
- Tape
- Tissue paper

### Preparation

- The diagnostics activities can be divided up among student groups to be completed as a jigsaw. The procedure below discusses how to administer the activities in this way. If you choose to administer the activities as a whole class, the individual teacher guide pages for each diagnostic can be found on pages 14-24.
- Divide the class into four groups using the list below. Each group will complete the diagnostics related to their group. If you would like smaller groups, you can have two Electrical Devices groups and two Building Envelope groups very easily working simultaneously.
  - Building Envelope
  - HVAC
  - EnergyGuide Labels and Appliances
  - Electrical Devices
- Before beginning the activities and giving the groups their instructions, go over the teacher guide pages for each diagnostic. These pages will provide the preparation needed for students to complete each task, any additional materials they will need, and any instructional points or clarifications that might need to be discussed with each group. You may also choose to appoint one student in each group as the group leader. The group leader may also take the teacher guide pages to make sure their group is completing the task appropriately. Be certain not to give students parts of pages that include answers.
- Make copies of any worksheets and handouts needed based on the chart on the next page and pages 14-24.
- Obtain necessary permission and approval from other building staff to allow students into other classrooms and rooms in the building.

### Procedure

1. Give each group the appropriate tools and in-class worksheets using the table on the next page and the teacher instructions. Students should review their tasks and begin collecting data. Allow groups at least 30 minutes to collect data from around the school building.
2. Groups should present their data to the class, and explain what the data means for the building's overall performance and the health and comfortability of its occupants. Groups should refer to the *Student Informational Text* if they need assistance or extra information related to their data and topic. Each student group should make sure their presentation gives the class enough information about why it is important to complete these diagnostics, how they completed them, and how to use the data to inform change in the home. Groups should go over the specific home investigation worksheets with the class so that the class is prepared to do the at-home activities related to each topic.

3. Hand the class the home investigation worksheets (listed in the table below), and a copy of the *Energy Conservation Contract*. Instruct students to conduct a home energy audit with their families. Students should begin by completing the *Energy Systems and Sources* worksheet with their parents. They should summarize their findings by completing the *Home Energy Use Survey*.
4. Assign students a timeline in which to complete their home diagnostics and worksheets. Students should bring the worksheets and contracts back to class and discuss the results.

	Class Worksheets	Home Investigation Worksheet
<i>Diagnostic 1</i>	Building Envelope <ul style="list-style-type: none"> <li>▪ <i>Windows Investigation</i>, page 58</li> </ul>	<ul style="list-style-type: none"> <li>▪ <i>Investigating Windows and Air Infiltration at Home</i>, page 59</li> <li>▪ <i>Investigating Home Insulation and Infiltration</i>, page 60</li> <li>▪ <i>Recommended R-Value Map</i>, page 61</li> </ul>
<i>Diagnostic 2</i>	HVAC <ul style="list-style-type: none"> <li>▪ <i>Temperature Investigation</i>, page 62</li> </ul>	<ul style="list-style-type: none"> <li>▪ <i>Investigating Thermostats at Home</i>, page 63</li> </ul>
<i>Diagnostic 3</i>	EnergyGuide Labels and Appliances <ul style="list-style-type: none"> <li>▪ <i>Reading EnergyGuide Labels</i>, page 64</li> <li>▪ <i>Comparing EnergyGuide Labels</i>, page 65</li> <li>▪ <i>Comparing Appliances</i>, page 66</li> </ul>	<ul style="list-style-type: none"> <li>▪ <i>Appliances and EnergyGuide Labels</i>, page 67</li> </ul>
<i>Diagnostic 4</i>	Electrical Devices <ul style="list-style-type: none"> <li>▪ <i>Kill A Watt® Monitor Instructions</i>, page 68</li> <li>▪ <i>Kill A Watt® Investigation 1</i>, page 69</li> <li>▪ <i>Kill A Watt® Investigation 2</i>, page 70</li> <li>▪ <i>Facts of Light</i>, page 71</li> <li>▪ <i>Comparing Light Bulbs</i>, page 72</li> </ul>	<ul style="list-style-type: none"> <li>▪ <i>Home Light Audit</i>, page 73</li> </ul>

## Diagnostic 1: Building Envelope

### ★ Objective

- Students will investigate windows and describe how to reduce air infiltration.

### 📄 Materials

- Pencils
- Tape
- Pieces of tissue paper (1" x 12")
- *Windows Investigation*, page 58
- *Investigating Windows and Air Infiltration at Home*, page 59
- *Investigating Home Insulation and Infiltration*, page 60
- *Recommended R-Value Map*, page 61

### 📋 Preparation

- Cut tissue paper into 30 1" x 12" pieces.

### ✓ Procedure

1. Begin the activity by discussing the advantages of windows in buildings and how they are related to energy in the home or building. Discuss how they can reduce the need for artificial light and how poorly constructed windows can allow cold air infiltration in winter and heat infiltration in summer.
2. Review the section of the *Student Informational Text* on Doors and Windows, on page 39.
3. Discuss the different types of windows and ways to prevent air infiltration through windows.
4. Go to *Windows Investigation*.
5. Distribute pencils, tissue paper, and tape to the group.
6. Instruct the group to tape the tissue paper to the ends of the pencils as shown in the diagram.
7. Instruct the group to examine the classroom windows and record their observations.
8. Discuss the group's observations and opinions of the energy efficiency of the windows that were investigated.
9. Instruct the group to then go to their work areas around the school building. Examine the windows in each area, and record observations.
10. Discuss the group's observations.
11. Go to the home Windows and home Insulation activities and review the instructions. Project the R-value map if needed.
12. Each student should take home a pencil with tissue paper and the activity page to complete the activity by the due date.
13. Review the activity upon completion and discuss as a class what was learned about their windows at home and at school.



## Diagnostic 2: HVAC

### Objective

- Students will be able to explain why heating and cooling systems in schools and homes use more energy than any other energy systems, and describe how to use these systems more efficiently.

### Materials

- 2 Digital humidity/temperature pens
- *Temperature Guide* master, page 16
- *Temperature Investigation*, page 60
- *Investigating Thermostats at Home*, page 61

### Preparation

- Prior to the lesson, arrange to have someone from the maintenance or facilities staff show the group the HVAC (Heating, Ventilation, and Air Conditioning) system and answer questions about the energy sources that fuel them. Schedule a time for the group to visit their work areas.

### Procedure

1. Begin the activity by discussing the importance of managing heating and cooling systems to save energy. These systems use more energy than any other systems in schools and homes.
2. Have the group inspect the school HVAC system with someone from the maintenance or facilities staff. Ask the staff member: Which system is in operation? What energy source fuels the heating system? What energy source fuels the cooling system?
3. Go to the *Temperature Investigation*, and go over the thermostat temperature guide at the bottom of the page.
4. Display or project the *Temperature Guide* master and discuss how to read it in both heating and cooling seasons.
5. Review the activity with the group, and choose who will be responsible for the humidity/temperature pen.
6. Instruct the group to complete the activity.
7. Review the results with the group using the *Temperature Guide* master.
8. Discuss whether any action should be taken if temperatures are not within energy saving ranges.
9. Discuss the relative humidity measurements and how this might affect human health and comfort.
10. Go to the *Investigating Thermostats at Home* activity and review the instructions.
11. Each student should take home the activity page and complete it by the due date.
12. Review the activity upon completion and discuss as a class what was learned about the temperature and humidity of the home and school environments.

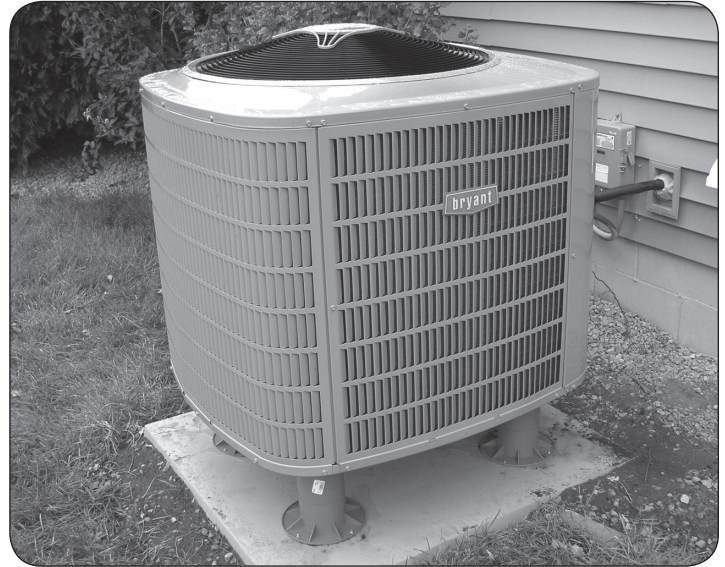



# Temperature Guide

## HEATING

ENERGY SAVING

ENERGY WASTING

-20%	-10%	0%	+10%	+20%	+30%	+40%	+50%	+++++	+++++
64°	66°	68°	70°	72°	74°	76°	78°	80°	82°
+++++	+++++	+++++	+++++	+++++	+++	+++	0	-10%	-20%

ENERGY WASTING

ENERGY SAVING

## COOLING

Classroom:

Office:

Gymnasium:

Cafeteria:

Library:



## Diagnostic 3: EnergyGuide Labels and Appliances

---

### Background

---

The Federal Government requires that appliance manufacturers provide information about the energy efficiency of their products to consumers. This enables consumers to compare the life cycle cost of the appliances, as well as the purchase price. The life cycle cost of an appliance is the purchase price plus the operating cost over the expected life of the appliance.

The law requires that manufacturers place EnergyGuide labels on all new refrigerators, freezers, water heaters, dishwashers, clothes washers, room air conditioners, central air conditioners, heat pumps, furnaces, and boilers. The EnergyGuide labels list the manufacturer, the model, the capacity, the features, the average amount of energy the appliance will use a year, its comparison with similar models, and the estimated yearly energy cost.

For refrigerators, freezers, water heaters, dishwashers, and clothes washers, the labels compare energy consumption in kWh/year for electricity or therms/year for natural gas. For room air conditioners, central air conditioners, heat pumps, furnaces, and boilers, the rating is not in terms of energy consumption, but in energy efficiency ratings, as follows:

- EER—Energy Efficiency Rating (room air conditioners)
- SEER—Seasonal Energy Efficiency Rating (central air conditioners)
- HSPF—Heating Season Performance Factor (heat pumps with SEER)
- AFUE—Annual Fuel Utilization Efficiency (furnaces and boilers)

The estimated annual operating cost is based on recent national average prices of electricity and/or natural gas. This cost assumes typical operating behavior. For example, the cost for clothes washers assumes a typical washer would be used to wash eight loads of laundry per week.

### Objectives

---

- Students will be able to read and analyze the information on EnergyGuide labels.
- Student will be able to compare the life cycle costs and payback period of several appliances using the information on their EnergyGuide labels.

### Materials

---

- *EnergyGuide Label* master, page 19
- *Comparing EnergyGuide Labels* worksheet, page 65
- *Comparing Appliances* worksheet, page 66
- *Appliances and EnergyGuide Labels* worksheet, page 67

## Preparation

---

- Make copies to share or project of the *EnergyGuide Label* master and *Comparing EnergyGuide Labels* worksheet.

## Procedure

---

1. Begin the activity by reviewing the *Reading EnergyGuide Labels* worksheet and the master of the *EnergyGuide Label*. Discuss why the Federal Government would be involved in labeling the efficiency of appliances.
2. Review *Comparing EnergyGuide Labels*, using the master. Introduce the concept of life cycle cost and payback period. Discuss how the chart shows that even though Model Two is more expensive to buy, it is a better bargain because of the lower energy costs over time. Point out the number of years for the payback period, and discuss how long appliances can last.
3. Complete the *Comparing Appliances* activity. Review.
4. Go to the *Appliances and EnergyGuide Labels* home activity and review the instructions.
5. Each student should take home the activity page and complete it by the due date.
6. Review the activity upon completion and discuss as a class what was learned about EnergyGuide labels and appliance efficiency.

## Extension Activity

---

Take a field trip to a building supply store or appliance store to examine and compare the EnergyGuide labels on large appliances. This can also be completed as a virtual field trip, as many appliance stores include a digital copy of the EnergyGuide labels for appliances they are selling on their websites.

U.S. Government

Federal law prohibits removal of this label before consumer purchase.

# ENERGYGUIDE

Refrigerator-Freezer

- Automatic Defrost
- Top-mounted
- No Through- the Door Ice Service

BRAND B

Model 1

Capacity: 21.1 Cubic Feet



**Compare ONLY to other labels with yellow numbers.**  
 Labels with yellow numbers are based on the same test procedures.

## Estimated Yearly Energy Cost

**\$49**

\$40

\$65



Cost range not available

**410 kWh**

Estimated Yearly Electricity Use

- ⊠ Your cost will depend on your utility rates and use.
- ⊠ Cost range based only on models of similar capacity with Automatic Defrost, Top-mounted, and No Through- the Door Ice Service.
- ⊠ Estimated energy cost based on a national average electricity cost of 12 cents per kWh.



[ftc.gov/energy](http://ftc.gov/energy)

## Diagnostic 4 - Part 1: Kill A Watt® Investigations - Electrical Devices

---

### Objective

---

- Students will be able to use a Kill A Watt® monitor to gather electrical consumption data from a variety of electrical devices in various modes and calculate the cost of using them.

### Materials

---

- Kill A Watt® monitor
- *Kill A Watt® Monitor Instructions*, page 68
- *Kill A Watt® Investigation 1*, page 69
- *Kill A Watt® Investigation 2*, pages 70

### Preparation

---

- Practice using the Kill A Watt® monitor until you are confident with its functions.
- Make copies of the *Kill A Watt® Monitor Instructions* to project or share.

### Procedure

---

1. Review the *Kill A Watt® Monitor Instructions*.
2. Point out the parts of the monitor, and demonstrate the operation and purpose of the device.
3. Review *Kill A Watt® Investigation 1* with the group. Select five electrical devices to monitor.
4. Divide the group into smaller groups and assign each smaller group to monitor one of the selected devices for a six-minute period. Have each group share its results with the larger group.
5. Have the students complete the computations and answer the conclusion questions.
6. Review with the group.
7. Repeat the process for *Kill A Watt® Investigation 2*.
8. Discuss how to save energy when using electrical devices, incorporating the data that has been gathered.

## Diagnostic 4 - Part 2: Lighting - Electrical Devices

### ★ Objective

- Students will be able to describe and quantify the differences in cost and efficiency of different types of light bulbs.

### 📄 Materials

- Light Bulb Comparison* master, page 23
- Comparing Light Bulbs* master, page 24
- Facts of Light*, page 71
- Comparing Light Bulbs*, page 72
- Home Light Audit*, page 73

### 📅 Preparation

- Make copies to project or share of the masters on pages 23-24.

### ✓ Procedure

1. Begin discussing lighting by discussing the many uses of lighting. Try to estimate the number of light bulbs in the building or each student's home.
2. Instruct the group to note the types of lighting in the classroom.
3. Discuss how classroom lighting is different from the lighting they have at home. Most lights in schools are fluorescent tubes. At home, incandescent and/or compact fluorescent bulbs are usually used.
4. Discuss that a compact fluorescent light bulb, or CFL, uses the same technology as a fluorescent tube. An even more efficient bulb uses light emitting diodes, or LEDs. These use a solid-state technology to produce light.
5. Go over the *Light Bulb Comparison* master. Note the cost of the bulbs and identify the important measurements on light bulb packaging:
  - Lumens—a measure of the amount of light a bulb produces
  - Watts—a measure of the amount of electricity a bulb uses
  - Life—the average length of time a bulb is expected to operate in hours
6. Instruct the group to use the information on the *Facts of Light* worksheet to complete the *Comparing Light Bulbs* activity. They will determine purchase costs and energy costs of incandescent, halogen, compact fluorescent bulbs, and LEDs. The electricity cost of \$0.125/kWh is the national average for residential consumers and \$0.10/kWh for commercial customers (schools). To reinforce real life connections, use the electricity cost of your local utility. For this activity, the master reflects the use of the national commercial electricity rate, \$0.10/kWh, however you could use either the residential or the commercial rate for this activity based on your discussion.
7. Discuss that the life cycle cost is the cost over the operating life of the bulb, not daily or monthly cost.
8. Display and go over *Comparing Light Bulbs* using the master. Have the group provide the data to complete the information on the master and determine the life cycle savings using more efficient bulbs.
9. Discuss why so many people use incandescent bulbs when they could save so much money and energy by switching to LEDs or CFLs. Also discuss the amount of carbon dioxide that is released to power the light bulbs for 25,000 hours.
10. Go to the *Home Light Audit* and review the instructions.
11. Each student should take home the activity sheet and complete it by the due date.
12. Review *Home Light Audit* upon completion, answer any questions, and discuss what the students learned from the activities about lighting efficiency.



#### **DID YOU KNOW?**

Only 10 percent of the energy used by a traditional incandescent bulb produces light. The rest is given off as heat.

## Extensions

- Encourage the class to install LED or CFL bulbs.
- Have students research the cost of incandescent bulbs and CFLs locally.
- Have the students compare the cost of electricity from your local utility with the national average.

## Cost of 25,000 Hours of Light ANSWERS

All bulbs provide about 850 lumens of light.



COST OF BULB	INCANDESCENT BULB	HALOGEN	COMPACT FLUORESCENT (CFL)	LIGHT EMITTING DIODE (LED)
Life of bulb (how long it will light)	1,000 hours	3,000 hours	10,000 hours	25,000 hours
Number of bulbs to get 25,000 hours	25 bulbs	8.3 bulbs	2.5 bulbs	1 bulb
<b>x</b> Price per bulb	\$0.50	\$3.00	\$3.00	\$8.00
<b>=</b> Cost of bulbs for 25,000 hours of light	<b>\$12.50</b>	<b>\$24.90</b>	<b>\$7.50</b>	<b>\$8.00</b>
COST OF ELECTRICITY	INCANDESCENT BULB	HALOGEN	COMPACT FLUORESCENT (CFL)	LIGHT EMITTING DIODE (LED)
Total Hours	25,000 hours	25,000 hours	25,000 hours	25,000 hours
<b>x</b> Wattage	60 watts = 0.060 kW	43 watts = 0.043 kW	13 watts = 0.013 kW	12 watts = 0.012 kW
<b>=</b> Total kWh consumption	1,500 kWh	1,075 kWh	325 kWh	300 kWh
<b>x</b> Price of electricity per kWh	\$0.10	\$0.10	\$0.10	\$0.10
<b>=</b> Cost of Electricity	<b>\$150.00</b>	<b>\$107.50</b>	<b>\$32.50</b>	<b>\$30.00</b>
LIFE CYCLE COST	INCANDESCENT BULB	HALOGEN	COMPACT FLUORESCENT (CFL)	LIGHT EMITTING DIODE (LED)
Cost of bulbs	\$12.50	\$24.90	\$7.50	\$8.00
<b>+</b> Cost of electricity	\$150.00	\$107.50	\$32.50	\$30.00
<b>=</b> Life cycle cost	<b>\$162.50</b>	<b>\$132.40</b>	<b>\$40.00</b>	<b>\$38.00</b>
ENVIRONMENTAL IMPACT	INCANDESCENT BULB	HALOGEN	COMPACT FLUORESCENT (CFL)	LIGHT EMITTING DIODE (LED)
Total kWh consumption	1,500 kWh	1,075 kWh	325 kWh	300 kWh
<b>x</b> Pounds (lbs) of carbon dioxide per kWh	1.23 lb/kWh	1.23 lb/kWh	1.23 lb/kWh	1.23 lb/kWh
<b>=</b> Pounds of carbon dioxide produced	<b>1,845.0 lbs carbon dioxide</b>	<b>1,322.3 lbs carbon dioxide</b>	<b>399.8 lbs carbon dioxide</b>	<b>369.0 lbs carbon dioxide</b>



# Light Bulb Comparison

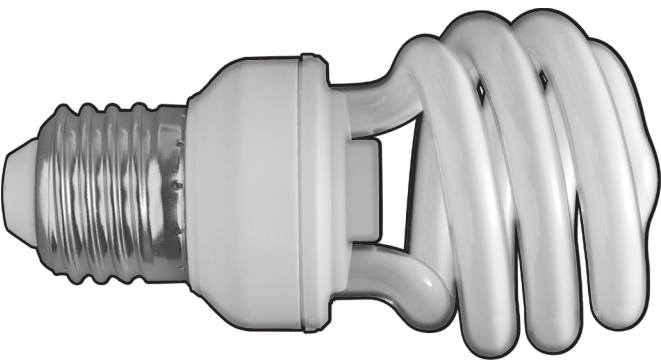

## INCANDESCENT BULB

## HALOGEN

## COMPACT FLUORESCENT (CFL)

## LIGHT EMITTING DIODE (LED)

Brightness	850 lumens	850 lumens	850 lumens	850 lumens
Life of Bulb	1,000 hours	3,000 hours	10,000 hours	25,000 hours
Energy Used	60 watts = 0.06 kW	43 watts = 0.043 kW	13 watts = 0.013 kW	12 watts = 0.012 kW
Price per Bulb	\$0.50	\$3.00	\$3.00	\$8.00



# Comparing Light Bulbs

All bulbs provide about 850 lumens of light.



## COST OF BULB

### INCANDESCENT BULB

Life of bulb (how long it will light)

1,000 hours

### HALOGEN

3,000 hours

### COMPACT FLUORESCENT (CFL)

10,000 hours

### LIGHT EMITTING DIODE (LED)

25,000 hours

Number of bulbs to get 25,000 hours

X Price per bulb

\$0.50

\$3.00

\$3.00

\$8.00

= Cost of bulbs for 25,000 hours of light

## COST OF ELECTRICITY

### INCANDESCENT BULB

Total Hours

25,000 hours

### HALOGEN

25,000 hours

### COMPACT FLUORESCENT (CFL)

25,000 hours

### LIGHT EMITTING DIODE (LED)

25,000 hours

X Wattage

60 watts = 0.060 kW

43 watts = 0.043 kW

13 watts = 0.013 kW

12 watts = 0.012 kW

= Total kWh consumption

X Price of electricity per kWh

\$0.10

\$0.10

\$0.10

\$0.10

= Cost of Electricity

## LIFE CYCLE COST

### INCANDESCENT BULB

Cost of bulbs

### HALOGEN

### COMPACT FLUORESCENT (CFL)

### LIGHT EMITTING DIODE (LED)

+ Cost of electricity

= Life cycle cost

## ENVIRONMENTAL IMPACT

### INCANDESCENT BULB

### HALOGEN

### COMPACT FLUORESCENT (CFL)

### LIGHT EMITTING DIODE (LED)

Total kWh consumption

X Pounds (lbs) of carbon dioxide per kWh

1.23 lb/kWh

1.23 lb/kWh

1.23 lb/kWh

1.23 lb/kWh

= Pounds of carbon dioxide produced



## Activity 6: Energy Web

---

### Objective

- Students will be able to describe the relationships of systems in the home or school and how they affect energy use, costs, and indoor air quality in buildings.

### Time

- Two 45 minute class sessions

### Materials

- Ball of yarn
- *Energy Web Hang Tags*, pages 26-29
- Clear plastic name badges (optional)

### Preparation

- Copy the *Energy Web Hang Tags* onto cardstock or paper. Cut out the cards (on the solid lines) and fold down the dotted line so the description of each term is now on the back of the card.
- Place one tag into each name badge holder if you have them. We suggest using ones that students can hang around their necks. If you do not have name badges, simply punch holes in the top of each tag and string yarn through the hole to make it like a necklace.

### Procedure

---

1. Hand out the role card hang tags and ask students to read the backs of their cards describing the term on the front. Give students a chance to ask any questions they have about what is written on their cards, or research if needed.
2. Have students put on their hang tags and stand in a circle.
3. Hand the ball of yarn to one of the students. Explain that he or she should look around the circle and identify another component of the system that is related to his/hers.
4. He/she should then hold on to the end of the yarn and pass the ball of yarn to that student, explaining how that part of the system relates to them. That student then repeats the process, holding onto the yarn and passing the ball on.
5. Continue passing the yarn around until everyone has their hands on the yarn. In the end, the students will have created a web made of yarn connecting all of them. Some students can be passed to more than once.
6. Now choose a student to give a tug on the string. Explain that this tug represents a stress of some sort on that part of the system. For instance, the person wearing the 'Heating System' tag might give a tug, and you would say, "There is something wrong with our heating system. It is not performing well, and is not running efficiently." Ask students to describe who also feels a "tug" and ask them to identify why they might be related.
7. Repeat this several times with different students tugging. For each tug, describe how the stress on one component is causing stress on the other parts of the system.
8. Ask students to describe how the system is dependent on all of the components. Students should be able to explain that a change in one part of the system can affect all other parts of the system—sometimes in unexpected ways!

## Lights

It's important to have good quality lighting at home and enough light to accomplish tasks.

Lights use electricity, which costs money and can contribute to pollution.

## Air Conditioning

AC helps you stay cool in hot weather. AC also removes moisture from your home, which helps you be more comfortable when the air is humid. In humid climates, drier air is also better for your health in the summertime.

AC uses a lot of electricity, which costs money and can contribute to pollution.

## Electric Bills

Electricity costs money. Whenever we use electrical appliances or lighting, we are charged for it.

This means there is less money available for other things your family needs and wants.

## Insulation

Insulation helps keep your house warm in winter and cool in summer. If your house is well insulated, the heating and AC systems don't have to work as hard.

Good insulation saves money on heating and cooling costs and can reduce air pollution.

## Clean Air

You need clean air to be comfortable and healthy. If too much air flows through your home, however, it removes heat, making the heating system work harder.

Sealing your home too tightly, on the other hand, can trap moisture, causing health problems.

## Weather

The weather greatly affects energy use.

The colder it is outside, the more it costs to heat a home. The hotter it is, the more it costs to keep it cool.

## People

You want to be comfortable in your home. That means you need heat in the winter, which costs money.

One way that people affect indoor air quality is by adding moisture to the air through their activities.

## Oil and Natural Gas Prices

Most homes are heated by a furnace that burns oil or natural gas.

When the cost of these fuels increases, it costs more to heat your home. The cost of these fuels usually rises during winter months.

## Moisture

Too much moisture in a home can lead to mold growth, which can cause health problems. Too little moisture in the air can cause health problems, too.

How does moisture get into your home? How does it get into the air?

## Household Budget

Your family has a limited amount of money it can spend each month.

The less money your family spends on energy, the more you can spend on other things that you need and want.

## Heating Bills

Heating your home uses a lot of energy and costs money. The more heat you use, the more your parents must pay.

This means there is less money available for other things you need and want.

## Hot Water

Heating water uses energy and costs money. Most homes use electricity or burn natural gas or oil to heat water.

The more hot water you use, the more your parents have to pay. This means less money is available for other things you need and want.

## Air Pollution and Global Warming

When you heat your home, the furnace is releasing emissions that can pollute the air. The electricity you use comes from a power plant, which may also add pollution to the air.

Many of these emissions can contribute to global warming.

## Heating System

The colder it is outside, the more fuel your heating system uses.

Insulation in the walls and attic can reduce the amount of heat your home needs, saving energy and money, and reducing pollution.

## Electrical Appliances

Refrigerators, TVs, and other appliances use electricity, which costs money. If you leave appliances on when they're not being used, that wastes energy. Appliances also add heat to a home. In the summer, that means the AC has to work harder, using more energy.

## Comfort

Comfort is important. You need heat in the winter; you need good lighting and clean air in your home. All of these use energy, which your parents have to pay for.

## Activity 7: High Performance House Design Project

### Objective

- Students will be able to visually showcase how building systems work together and how efficiency and conservation measures affect these systems.

### Time

- 60 minutes or more

### Materials

- Roll of clear packing tape
- 10 Pieces of heavy transparency film
- Roll of rope caulk (available at hardware stores)
- Probe thermometer
- 2 Stackolator bases
- Mini-blower door
- Rulers
- Scissors or x-acto knives
- Construction supplies: foil, bubble wrap, padded paper, cardboard, poster board, weatherstripping, etc.
- *House Design Project* worksheets, pages 75-78

### Preparation

- Familiarize yourself with the teacher and student activity instructions.
- Make copies of the *House Design Project* worksheets for each student, and the *Student Informational Text*, if you haven't already done so.
- Gather the materials needed.
- Organize students into groups of three.
- Ask students to help supply recycled materials for their house designs - cardboard, poster board, etc.
- Once you have gathered the suggested construction supplies and/or alternatives, verify the list and pricing of each item found on page 76.

### Procedure

1. Start by reviewing the informational text and specifically discussing the movement of heat, air, and moisture into and out of the home. Ask students to give examples of how these elements affect the home and how they can be controlled. Be sure students have also read the section, *What Does a Building Analyst Do?*, and have an understanding of how a blower door is used to test the air flow through a home.
2. Explain that they will be following the steps of a design process. They will be designing and constructing a model house that limits the movement of heat and air. They will be required to work within a budget and follow a building code. After the houses are built, they will be tested to determine how effectively they limit heat transfer and air movement, while providing enough fresh air to create a healthy indoor environment.
3. While this high-performance house may not include features that reduce electricity consumption or address the ability to have on-site generation of electricity from renewable sources, emphasize that these are also important for long-term sustainability. This design process addresses the most basic aspect of high performance housing by making the building envelope perform effectively. Students should be encouraged to experiment with features that save electricity or generate electricity for their homes as an extension to the activity.
4. Discuss the importance of providing adequate fresh air in the home. Let students know that when they are sealing up their home, they will need to allow for some airflow in order to ensure the health of those living in the home.
5. Show students the testing equipment (blower door, Stackolator, probe thermometer). They will be required to cut two circular holes in the bottom of the house to incorporate the Stackolator bases (see template). The bulbs in the bases will provide a heat source for the home. The temperature will be measured by inserting a probe thermometer into the house. Show students what materials you will provide them with and what materials they must purchase. Remind them they will NOT cut holes until the blower door testing is completed.

6. If using the blower door, explain its operation. Students will be required to size the front door of the house to accept the blower door. (You may adjust the required door dimensions, if necessary, to allow the blower door to fit.) It is comprised of a small box with a fan at one end and a hinged flap at the other. The higher the air flow, the higher the flap will rise. Thus, in a house that is well sealed, the flap will rise very little, if at all. The scale on the side of the device provides a way to measure the air flow and make comparisons between houses.
7. Distribute the worksheets to the students and place them into groups.
8. Review the procedure for the activity with them, along with any group and safety rules you have. In particular, review the steps in the design process:
  - Design Problem
    - Define Design Problems
    - Research
    - Planning
    - Develop Specifications
    - Construction
    - Evaluation
9. Share the rubric on page 32 with students.
10. When students have completed the construction of their houses they can be tested. If using the mini-blower door, test with this device first. For each house, insert the fan into the front door. Turn the fan on and direct students to observe the flap and the gauge. Three zones are indicated on the gauge. If the flap rests in the lowest red zone, it indicates a house that is too tight. There is not enough air flow to provide a healthy indoor environment. If the flap is in the green zone, there is adequate air flow and the air flow is not so high as to cause a concern with energy use. If the flap is in the highest red zone, the air flow is higher than necessary and the house can be sealed more tightly to reduce energy use. Discuss results with students and implications for modifying their design and/or construction. Refer students to the building code and explain the role of the ventilation inlet. Students can re-test their homes after modifications.
11. After students have completed modifications based on mini-blower door testing, they will use the template provided on their sheets to cut holes in the bottoms of their houses. These holes will accommodate the Stackolator bases. Place one house on the bases, and insert a probe thermometer 3 cm above the front door. Students should record the room temperature and the temperature inside the house on their *Conduction Test Results* chart on page 76. Turn on the Stackolator bases and leave them on for 15 minutes. After this period, students should take a second measurement of the inside room temperature.
12. Post or share the results of the temperature testing and promote a class discussion and sharing of ideas and strategies for design/redesign. Allow students to make modifications to their designs/construction based on the results.
13. Discuss the energy savings that insulation and air sealing can produce, especially in the context of cost—the more material you use, the more energy savings you will see. At some point, however, the increase in cost is not economically feasible when you compare the amount of energy saved, or you reduce the amount of usable space by too much. Materials that are really good insulators usually cost more than less-efficient insulators, so you need to consider the trade-offs and balance the energy saved with the cost.

### Balanced Ventilation

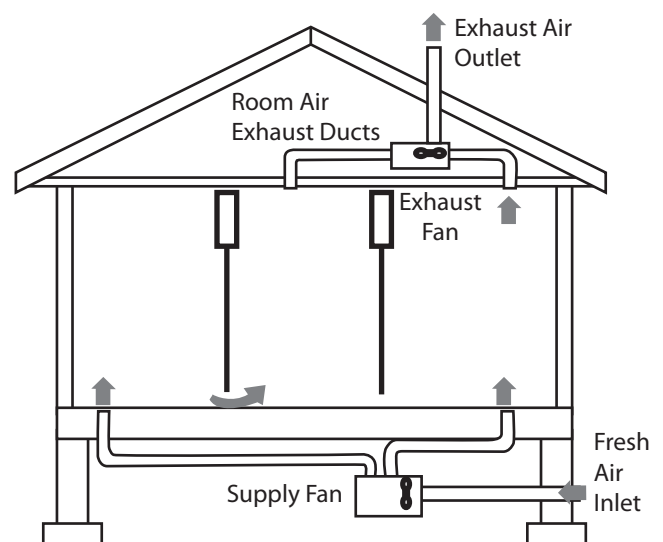

The best way to provide fresh air to a house is to seal it tightly and then control the amount of air through it with a ventilation system such as this.

**CONTINUED ON PAGE 32**

**CONTINUED FROM PAGE 31**

14. Discuss the results of the mini-blower door testing. Point out any designs that required a ventilation damper or vent to control flow. Explain that sealing to this point and adding this feature is an ideal strategy. It allows the homeowner control over the amount of air coming into the home. Explain that in actual houses, this would be a ventilation system and might include fans to exhaust air along with inlets that bring in fresh air. Use the diagram on the previous page to illustrate.
15. Discuss other materials the students could have used as insulation. Discuss what the students would change if they could do the activity again with additional materials.

 **Extensions**

- Have the students draw blueprints of their houses to scale or using digital design software. Have them devise written plans to insulate their houses before they begin the activity.
- Have the students design an experiment to explore the insulating qualities of materials with which houses are made, such as wood, brick, stucco, block, etc.
- Have students research heat recovery ventilators (HRVs) and present the advantages of this type of system in cold climates. These systems use a heat exchanger to remove the heat from air being exhausted from the home and send that heat back into the house.
- Have students include small lights, fans, or other devices that use electricity, and outfit their homes with solar panels or wind turbines that generate electricity.
- Have a building contractor visit the class to discuss energy-saving materials and techniques in the building industry.
- Assign students a budget for their house design project and attribute costs to the construction materials.

 **Evaluation**

- Evaluate individual student performance using the graphic organizers, worksheets, and science notebooks as appropriate.
- Evaluate presentations for the *House Design Project* using the rubric below.
- Evaluate the entire unit with your students using the *Evaluation Form* on page 79 and return it to NEED.

**House Design Project Rubric**

Category	3	2	1	0
Research and Planning	In addition to evidence of thorough research, relevant experiments were conducted to test design ideas.	Science notebook indicates several research questions were asked and answered effectively.	Science notebook indicates minimal research or planning was undertaken.	No evidence of research or planning leading up to design and construction.
Design and Construction	In addition to meeting project goals, construction was neat and of high quality.	All building codes and budget restrictions were followed. House air leakage was within a range that optimized energy use and occupant health. House was effective at maintaining temperature.	Some building codes were not followed and/or home air leakage rate was too high or too low and/or house was ineffective at maintaining temperature.	Many building codes not followed. Construction is sloppy and house performs poorly as a result. Budget was not followed.
Evaluation	Team effectively evaluated all aspects of the design process and made necessary improvements to improve performance.	Evaluation was conducted, but did not include all steps of the process and /or improvements to performance were modest or not present.	Minimal evaluation did not lead to any improvement in product.	Team did not evaluate their project and/or did not make any improvements.





# Student Informational Text

You've probably heard politicians and business leaders talking about the importance of saving energy and finding renewable energy resources. And, if you're like most students, you probably think there isn't much you can do in this area. Nothing could be further from the truth. There are many things you can do to help reduce the amount of energy we use. The purpose of this unit is to show you how you can go beyond turning the lights off and really understand how your house works—and doesn't work—as it uses energy.

Before we look at all of the ways a house uses energy, it's important to understand exactly what a house does. It's more than just a place to keep all of your stuff and go to sleep. A house provides shelter from extreme weather conditions and factors into keeping our living environment healthy and comfortable. As a species, humans spend a lot of time and energy creating a good place to live, and rightfully so. If you were forced to live outdoors your body might be subjected to very hot temperatures in the summer and deadly cold temperatures in the winter. You would get wet every time it rains, and when the wind was howling you would have a difficult time staying warm. The result would be an immune system that was stressed, and you may become sick much more often than you already do. It is important to maintain an environment that keeps us comfortable. You might not realize it, but comfort plays an important role in keeping us healthy.

## House as a System

### What is a System?

A system is a group of interacting, interrelated, or interdependent parts that function together as a whole to accomplish one goal. Everything around us is made up of systems and subsystems. Subsystems are the individual pieces that work together to create a system.

Your home is an interactive system consisting of the building itself, all of the working parts inside, including the heating/cooling systems, and those who live there. Your home should be a safe place to spend time regardless of what the weather is like or if it is day or night. A home cannot make you healthy, but it can make you unhealthy. The parts of the house system must work together in order to function well. Problems with one aspect of the system can affect all others.

A home system that is working effectively and efficiently will use less energy resulting in lower energy bills. A home system that is not working effectively or efficiently will often have higher energy bills. Understanding the parts of the house system, how they work, and how they use energy, allows us to assess how well our home is functioning as a whole system. Using this information, we can be more proactive in doing our part to make our homes more efficient, comfortable, and healthy.

## WHERE WE LIVE



Our homes, whether a house or an apartment, provide shelter, safety, and comfort.

### Heat, Air, and Moisture Flow

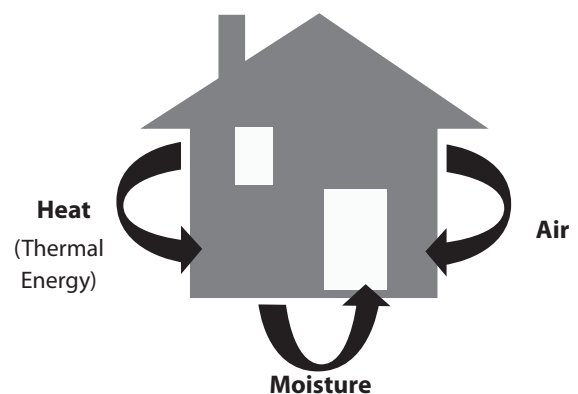

Heat, air, and moisture are constantly moving in and out of a house. In a high performance home, the homeowner is in control of the rate at which these movements occur.

## House as a System

**BUILDING ENVELOPE**—This component includes everything that creates barriers between indoors and outdoors—walls, floors, roofs, windows, and doors.

**LIGHTING**—This component includes table lamps as well as built-in light fixtures such as recessed ceiling fans or fixtures above sinks. The type of lighting used in these fixtures makes an important impact on home energy use.

**OCCUPANTS**—Buildings do not use energy themselves without being instructed to do so. The habits of the building's occupants play a big role in how much energy a house system consumes.

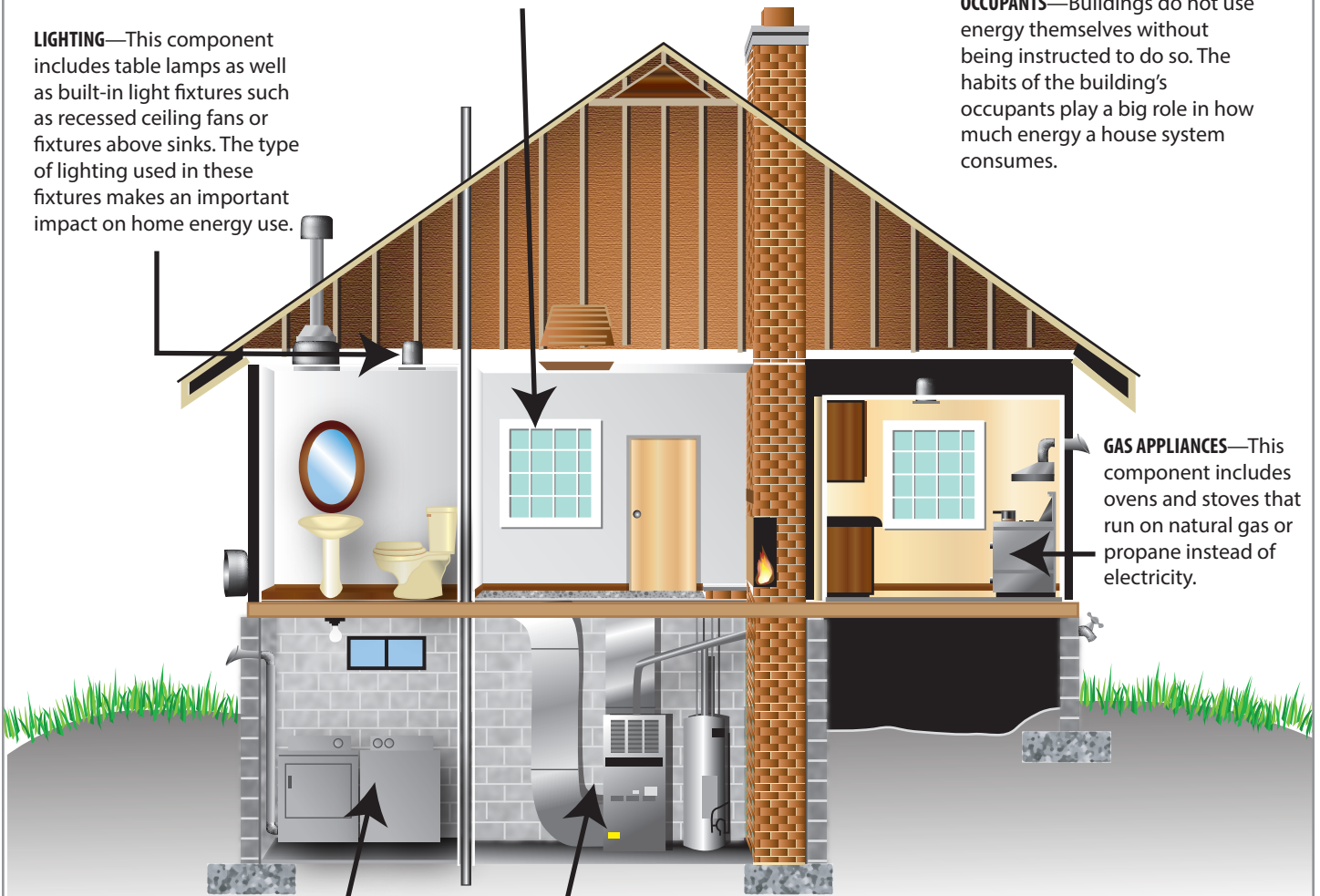

**GAS APPLIANCES**—This component includes ovens and stoves that run on natural gas or propane instead of electricity.

**ELECTRICAL DEVICES AND APPLIANCES**—Everything that is plugged into electrical outlets (except lights), such as computers, TV's, digital clocks, and other electronics, along with refrigerators and laundry appliances are classified in the electrical devices and appliances category.

**HEATING, VENTILATION, AND AIR CONDITIONING (HVAC) SYSTEMS**—This component includes the equipment that provides heating, cooling, hot water, and fresh air to the home. It also includes the devices that control the equipment, such as thermostats. This component uses more energy than any of the others and is greatly affected by the quality of the building envelope.

## How Our Homes Use Energy

When looking for ways to save energy in a home, it is important to maintain the health and comfort of the occupants. After all, the primary reason energy is used at home is to provide a comfortable and healthy environment.

We have specific requirements for temperature, relative humidity, and general air quality. We also have requirements for the quality and quantity of lighting. Poor air quality at home can lead to an increase in cold-like symptoms, allergies, headaches, and other symptoms.

Turning off lights and lowering the heat in winter can save energy, but doing so without consideration of the impact on those living there can cause unsafe or unhealthy conditions in the building. When the building is treated as a system, energy is saved while maintaining or improving the indoor environment.

### Heat, Air, and Moisture Overview

The three main factors that affect the home's energy use and the comfort and health of the occupants are heat, air, and moisture. These three elements are constantly moving into and out of the home. When designing new homes or improving existing ones, we want to put the homeowner in control of the flow of heat, air, and moisture. Without this control, issues can occur that increase energy use and decrease indoor air quality.

#### Heat Transfer

Thermal energy, or heat, is a form of energy associated with the movement of atoms and molecules in any material. The faster the atoms are moving, the greater the amount of energy, which is measured by the increase of temperature.

As mentioned, thermal energy is always moving into and out of the home. Thermal energy always flows from areas of higher temperature to lower temperature. This heat transfer occurs in three ways: conduction, convection, and radiation. Understanding the differences between these mechanisms is important to limiting heat transfer into and out of a home. If we know which heat transfer mechanism is likely to occur, it enables us to treat the heat loss or gain effectively.

#### CONDUCTION

This is the transfer of thermal energy between objects that are in contact with each other. The heat transfer occurs through a substance from molecule to molecule by direct contact. The molecules themselves do not necessarily change position, but simply vibrate more or less quickly against each other. When you hold a mug of hot chocolate, you can feel the heat conducting directly from the mug to your hand. In a house, heat is conducted through the walls, floors, ceilings, doors, and windows.

#### CONVECTION

Have you ever watched a lava lamp? If so, you were watching the effects of heat transfer via convection. When a fluid is moving because of uneven heating, convection is occurring. In the lava lamp, the moving fluid is heated by the light bulb at the bottom. The heated fluid becomes less dense than the surrounding fluid, and rises. As it rises, it cools, becoming denser, which causes it to fall back to the bottom.

### Thermal Energy Flows

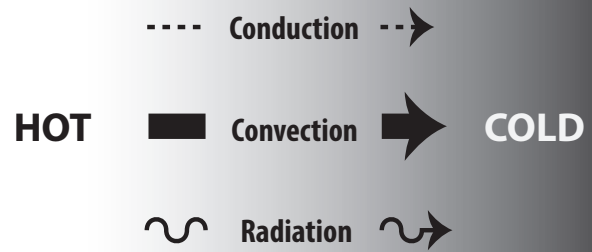

Thermal energy is always moving. It flows from areas of higher temperature to areas of lower temperature. Heat transfer occurs via conduction, convection, and radiation.

### Convection in Gases

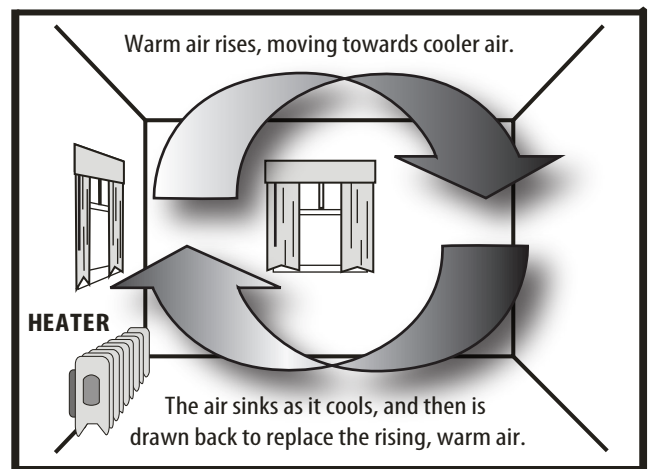

Though it is harder to see, this same process occurs in air. For example, air on the Earth's surface warmed by intense sunlight, will be heated by contact with the ground, expand, and flow upward, creating a region of low pressure below it. Cooler, surrounding air will then flow in to this low pressure region. The air circulates by convection, creating winds. In winter time in colder climates, warm, heated air in a house rises due to convection, and can pull in cold air through cracks at the bottom of the house. The warm air can escape from the house and into the attic increasing heating costs.

#### RADIATION

If you have ever been by a campfire, you have noticed that the side of your body facing the fire is much warmer than the side facing away. This is because thermal energy is being released, or emitted, by the fire and then being transmitted to you across the space between. Infrared radiation (sometimes called radiant heat transfer) is the process in which energy is emitted by a warmer body, to another body. Infrared radiation does not require a medium to travel through, but it can occur through air or liquids. Some electric heaters rely on radiant heat transfer. These heaters are not designed to heat the air in the room; rather they transmit their heat directly to people and objects in the room.

## ■ Air Movement

Air naturally moves into and out of our homes all the time—and it's a good thing. A regular flow of fresh air is necessary to replace the air in our homes that contains odors or high levels of moisture. Exchanging air also helps keep chemicals in the air from everyday materials like cleaning supplies and cosmetics at healthy levels. Most homes also have a way to remove air from locations where odors or moisture tend to build up, such as bathrooms and the kitchen.

Areas inside or outside of the home can have different levels of air pressure. When there is an opening between two adjacent areas (or zones) with different air pressure, air will flow. A simple example of this is a balloon. If you blow into the balloon to inflate it and hold it closed, the area inside has a higher pressure than the surrounding air. If you let go, the air will move quickly through the opening from the area of high pressure inside the balloon to the lower pressure air outside. Similarly, air moves in and out of a house through gaps and cracks. Most homes have too much air circulating because of gaps around doors, windows, and attic access panels. Excess air flow leads to higher energy use and costs when heating and cooling the building.

Understanding what drives air movement can help us control air flow in our homes. The following factors drive air flow:

### CONVECTION

Convection in a home results in a dynamic known as the “Stack Effect.” The diagram to the right shows how the warm, heated air rises up and escapes through cracks into the attic, drawing in colder air into the basement. When this happens, your house is acting like a smoke stack, which is designed specifically to move large amounts of thermal energy out of a building.

### WIND

As wind hits the side of a house, it creates an area of high pressure that drives air into the house, through any cracks or gaps. On the opposite side of the house there is an area of lower pressure where air from inside the house will tend to be drawn out through cracks and gaps. This can be a significant source of air leakage in a home that is in a windy location.

### FURNACE/AIR HANDLER

If there is a furnace or central air conditioning in your home, you have probably noticed how air flows out of the vents or registers. There are also registers that pull air from the room and return it to the air handler. The air handler is a large fan in your furnace or central AC system that is connected to the ducts that carry the air to and from the rooms in your home. These systems are strong enough to create areas of higher or lower pressure in certain rooms. When these systems are not balanced correctly, the pressure differences can greatly increase the rate at which air leaks into or out of the house. There are several other appliances that can cause areas of low pressure in the home because they pull air from the house and send it outside. Water heaters and furnaces need air for combustion and many will pull it from the house. Exhaust fans and clothes dryers both pull air from the house and send it outside in order to accomplish their tasks. As these appliances create a lower pressure condition, air is naturally pulled into the home from outside.

## Heat Transfer Arrows

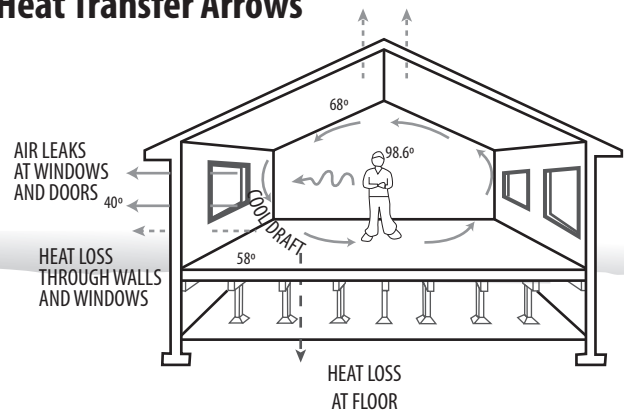

## Stack Effect

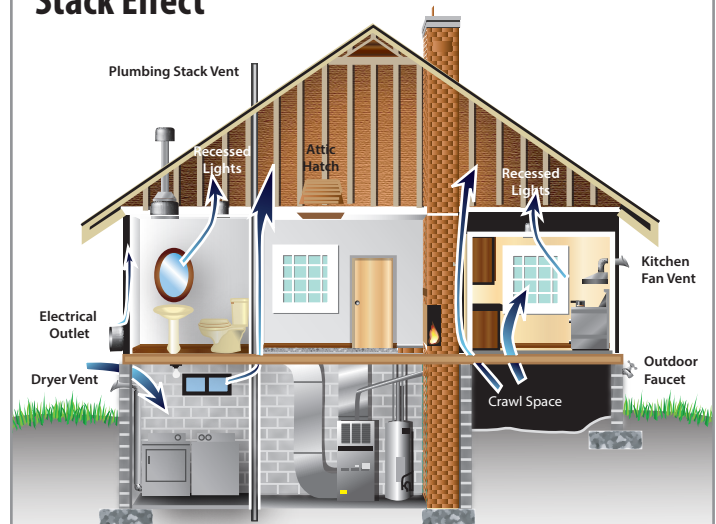

The “Stack Effect” occurs when a building is heated, and the warm air inside the building is less dense than the colder air outside.

## FURNACE



Furnaces can create differences in air pressure throughout a house. This can affect the rate at which air moves in and out of the house.

▪ **Moisture**

Moisture is a term used to describe water in both liquid and vapor or gaseous form. Like heat and air, it is important to have the right amount of moisture in the home. Most moisture in a home exists as water vapor. The amount of water vapor in the air plays an important role in determining our health and comfort.

Humidity is a measurement of the total amount of water vapor in the air. Relative humidity measures the amount of water vapor in the air relative to the amount of water vapor the air is able to hold, which depends, in part, on the temperature of the air.

As air warms, it tends to hold more water vapor because liquid water absorbs heat from the air. This gives the molecules the energy needed to make the change to the gas phase.

It is important to control moisture and relative humidity in occupied spaces. Relative humidity levels that are too high can contribute to the growth and spread of unhealthy biological pollutants, such as mold and mildew. This in turn can lead to a variety of health effects such as allergic reactions and asthma attacks. Humidity levels that are too low, however, can contribute to irritated mucous membranes, dry eyes, and sinus discomfort. Relative humidity should be kept between 40 and 60 percent to ensure that a building's occupants are both comfortable and healthy.

In cold climates in the winter time, it is common to experience dry indoor air. You may have experienced chapped lips or dry skin. These conditions can also lead to respiratory problems and an increase in cold-like symptoms. Because cold air cannot hold as much water as warm air, when cold, dry air from outside enters the home and is warmed, the relative humidity in the home goes down. Dry air creates a challenge for keeping the temperature constant.

Moisture can enter the home either as vapor or as liquid water. Air moving in or out of a building carries some moisture with it. Sometimes the amount of moisture in the air is minimal, but other times it is significant. On warm, humid days, very moist air entering the home can make it uncomfortable and harder to keep cool. This moisture can condense if it comes into contact with a cool surface. Many people use dehumidifiers in humid climates to remove moisture from the air, condensing the water in one location where it can be collected and removed.

Sometimes moisture is generated inside the home. Cooking releases water vapor, and showers are another common, indoor source. If this moisture is not removed from the home it can cause the problems discussed earlier. The best way to control moisture originating inside is to remove it with an exhaust fan. Bathrooms and kitchens often have exhaust fans that remove water vapor from these locations.

Once liquid water enters the home from outside it can cause several problems, from mold growth to the rotting of building materials. Water usually enters through leaky roofs or basements. Where the water table is high, or in areas prone to flooding, water enters basements during wet times of the year. If the drainage around the house is inadequate, water can seep into the basement.

The best way to control a moisture problem is to identify the source of the moisture and eliminate it. Basements frequently flooded by groundwater are usually equipped with a sump pump, which automatically removes water as it collects. If rainwater is entering the home, gutters may need to be installed, or the yard might need to be leveled to direct water away from the house.

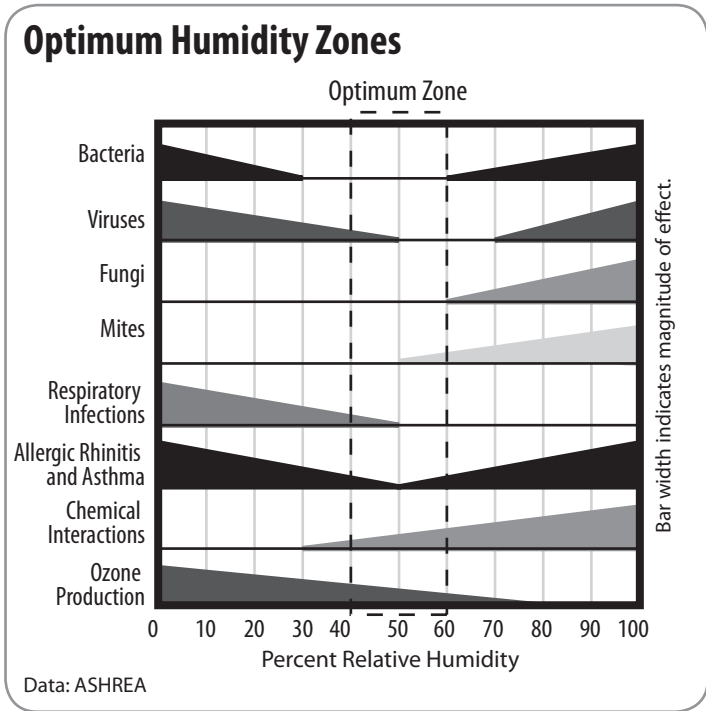

**It's a System...**

Controlling the air movement into and out of your home can actually affect the amount of moisture in your home.

**KITCHEN EXHAUST SYSTEM**



Kitchen exhaust fans remove moisture from the air, which prevents mold growth and other related problems that can occur from excess water vapor.

## Using and Saving Energy in the House System

### Building Envelope

The transfer of heat, air, and moisture into and out of the home is largely governed by the building envelope, which is made up of all the components that separate the inside of the home from outdoors. Siding, windows, doors, and roofs have an important role to play, as does how tightly the various parts of the building are sealed to one another.

### Insulation

Insulation in the walls and attics plays a very important role in controlling heat transfer. Insulation is effective because it contains many, tiny air pockets. When thermal energy has to move through trapped air it is slowed down because air does not conduct heat very well compared to most materials. This is because air molecules are farther apart from one another than the molecules in solids or liquids. Materials used for insulation are effective because they create these air pockets. Most types of insulation only slow heat transfer via conduction. In these materials, thermal energy can still transfer through via convection.

The type of insulation used is determined by both where it will be used and how much it costs. There are many types of insulation used in buildings today.

- Cellulose is made from ground up newspaper that is treated with a flame retardant to minimize risk from fire. It comes in large bales and is installed using a machine that blows the insulation through a hose.

It is common to see this type of insulation in attics as loose fill. It is also used to insulate walls in homes that have no insulation in these locations. In walls, cellulose is packed tightly enough into the cavity that it also stops air movement preventing heat transfer via convection.

- Fiberglass insulation is made of tiny threads of glass that are meshed together. Fiberglass insulation is most used in long rolls called batts. Sometimes there is a paper or foil facing on one or both sides of the roll. The rolls are sized so that batts fit snugly between the rafters or wall studs of most homes. Some forms of fiberglass insulation can also be blown into an attic or a wall just like cellulose.
- Foam insulation comes in many forms. Some foam insulation comes as a liquid and is sprayed or blown like cellulose. However, it may not be used in enclosed walls the way cellulose and fiberglass can. Other types of foam insulation are provided as solid boards. These are useful for attaching to walls and ceilings. Some types of foam insulation can stop air movement, preventing heat transfer via convection.

The effectiveness of insulation is measured by R-value. R-value is the rating that is used to indicate the resistance of the material to heat transfer. The higher the R-value, the more effective the material is at reducing heat transfer.

No matter what type of insulation is used, it has to be installed properly. Insulation that gets compressed is much less effective because so many of the trapped air spaces have been eliminated. Another common way that insulation's effectiveness is reduced is when there are gaps.

### CELLULOSE INSULATION



Image courtesy of Community Services Consortium

### FIBERGLASS INSULATION



Image courtesy of Owens Corning

### Insulation R-Value

Insulation Type	R-Value Per Inch of Insulation	Typical Applications
Cellulose, loose fill	3.7	Attic Floor
Cellulose, high density	3.2	Walls, Enclosed Cavities, Framing Transitions
Fiberglass, batts	3.0	Basement Ceiling, Open Stud Walls, Attic Floor
Foam board	7.0	Foundation Walls, Attic Access Doors

Data: Building Performance Institute

## ▪ Air Sealing

Air, carrying thermal energy with it, can leak in or out through small cracks. Often the many small cracks in a home add up to a hole the size of a wide open door. Some of these cracks are obvious—around doors and windows, for instance. But others are hidden behind walls and above ceilings. Due to the stack effect, in colder climates, the attic floor is usually the place where the most air leaks out of a house. Unseen cracks and hidden air pathways inside the home can be the largest sources of uncontrolled heat transfer in the house.

To prevent air leaks, caulk, seal, and weather-strip all cracks and openings to the outside. Some of these cracks can be sealed by the homeowner, but the greatest savings will be gained by hiring a company specializing in finding and sealing hidden leaks in the attic.

## ▪ Doors and Windows

Doors and windows are an important part of the building envelope. They allow occupants easy access between the inside and outside world, but these are also areas that should be checked carefully to ensure that they are working efficiently.

The best windows shut tightly and are constructed of two or more pieces of glass. Any cracks around the window frames should be caulked and the windows checked often to make sure they seal tightly. Any cracked glass should be replaced. In some double-paned window systems, a heavy gas is used to fill the space between the panes. This gas slows down heat transfer by convection. Some windows also have coatings that allow sunlight in, but are effective at reflecting thermal energy radiating from within the building back inside.

Older windows in a home can be treated to make them more energy efficient. Weatherstripping can be used to create a tighter seal between the window and the frame. There are many types of weatherstripping. For windows, use a spring-type weatherstripping, which is a strip installed along the window frame on the track on which the window moves up and down. The most durable type is made of brass. It is a strip folded in half so as to spring against both the window and the frame creating a tight seal. Foam weatherstripping, while not as effective, is easy to find and install.

Doors to the outside should seal tightly and have door sweeps at the bottom, as well as weatherstripping around the frame to prevent air leaks. Use rubber “stop-type” weatherstripping for doors. This is installed in the frame as a strip and has a thick “bulb” that squeezes tightly into the crack when the door is closed. Door sweeps are flexible, rubber strips that are installed at the bottom of a door to prevent air movement under the door. If the door has windows in it, they should be sealed tightly.

### It's a System...

Sealing a home to save energy can cause problems with moisture and indoor air quality if not done properly.

## AIR SEALING MATERIALS

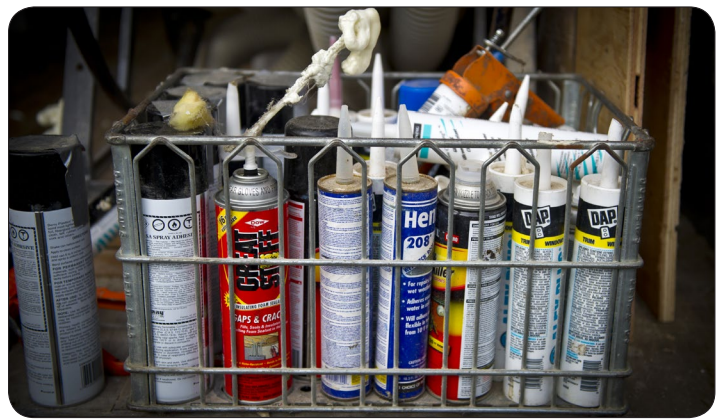
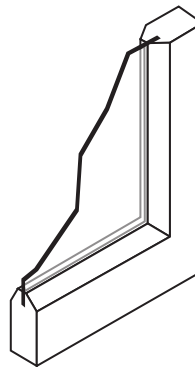

Photo Credit: Dennis Schroeder, NREL

## Window Glazing Types

LEAST EFFICIENT

MOST EFFICIENT



### SINGLE

often has storm window, screen, or combination

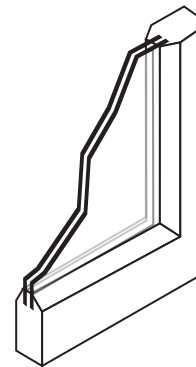

### DOUBLE

space between glass may be gas-filled  
glass may be low-E type with coatings

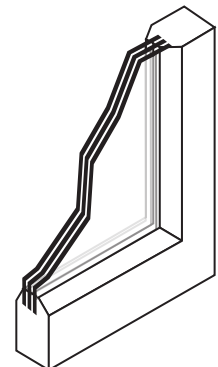

### TRIPLE

space between glass may be gas-filled  
glass may be low-E type with coatings

## INSTALLING A DOOR SWEEP



## Materials and Techniques Used by Installers

Homeowners can take many different measures to improve the building envelope. You can conduct an informal home audit to determine where there might be problems with the building envelope. You may already be aware of problem areas if a room always feels hotter or colder than the others.

Individuals can fill in small cracks with caulk. When remodeling, the proper insulation can be chosen for the space, and weatherstripping can be added around door frames and windows to fill in spaces where larger amounts of air are getting through.

In some cases, the building envelope needs more extensive work and it is best to hire a professional. Because of the stack effect, this work usually focuses on the attic. Installers use a variety of materials to seal hidden air pathways. Caulk, liquid foam, foam board, and sheet metal are some examples. Whatever material is used, the installer ensures that a barrier is used that does not allow air to pass through it and that it is sealed in place with an airtight sealant such as foam or caulk.

When a home is built or when an existing home is sealed, it is necessary to keep in mind the need for fresh air for those who live there. While even after air sealing most homes have enough natural air leakage to provide healthy indoor air, some houses might need to add exhaust fans or more elaborate systems. A home performance professional will test a house before any work is done to see how leaky the house is and then will test it again after sealing to make sure it is safe for those living there. This is done with a device called a blower door. A variable speed fan and air gauges are used to measure the amount of air moving through the fan as well as the difference in pressure between inside and outside. A technician will close all doors and windows to seal the building as tightly as possible and then pull air out of the house using the fan. This forces air in through all of the hidden leaks. The measurements taken from the gauges allow the technician to quantify the leakage and compare it to standards in order to determine if a house is too leaky or too tight. This test is conducted before sealing the house and again afterwards. Sometimes it is even used while the house is being air sealed to give the crew feedback on the effectiveness of their efforts.

Another tool used is an infrared (IR) camera. An IR camera is a device that forms an image using infrared radiation. It is similar to a regular camera that forms an image using visible light, but instead senses longer wavelengths of energy that indicate radiant heat transfer. Using the IR camera, the home performance professional can find areas of heat loss or heat gain in a home. When used with the blower door, the IR camera can also show hidden air leakage paths inside the walls and floor cavities of the house.

## Diagnostic Tools

Testing the airtightness of a home using a special fan called a blower door can help to ensure that air sealing work is effective. Often, energy efficiency incentive programs, such as the DOE/ EPA ENERGY STAR® Program, require a blower door test to confirm the tightness of the house.

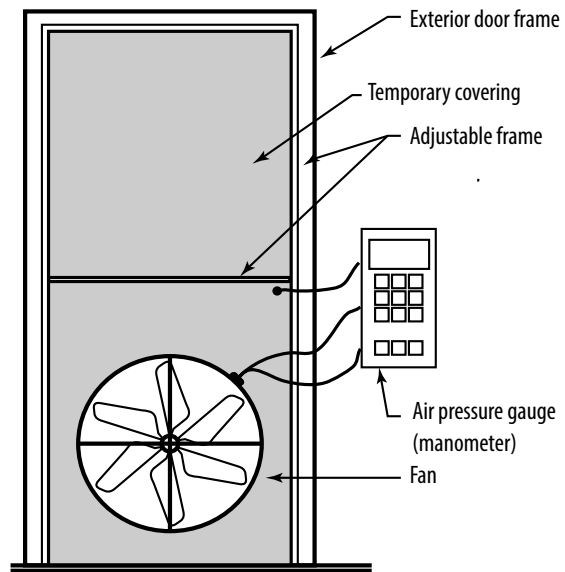

## INFRARED CAMERA



The dark strip in the middle of the camera screen indicates that the wall at the corner of the room is colder. In most homes there is less insulation in corners leading to increased heat transfer in these areas.

## It's a System...

If a home is well insulated and sealed, it can use a smaller heating system, which will use less energy.



## HVAC

Heating and cooling systems use more energy than any other systems in our homes. Natural gas and electricity are used to heat most homes, and electricity to cool almost all. About 50 percent of the average family's energy cost is for keeping homes at comfortable temperatures. The energy sources that power these heating and cooling systems also emit carbon dioxide into the atmosphere each year, which contributes to the greenhouse effect.

In most furnaces and boilers, natural gas, heating oil, or propane is burned to heat the home. In a furnace, air is heated and then distributed to the home through ductwork to heating registers in rooms. Return air registers bring air back to the furnace from the home to be reheated. Boilers, however, heat water instead of air. Hot water, or sometimes steam, is distributed to the house through pipes. In the case of boilers, pumps move the water. In steam systems, the steam pressure itself causes the steam to move through the pipes. In either case, pipes return water to the boiler where it is reheated and re-circulated. Today's high efficiency boilers and furnaces are rated 20 percent more efficient than older appliances.

Electric heaters are also used in many homes. Most heaters are installed as long radiators that run along the bottoms of the walls and are wired into the home's electrical system. Other, smaller heaters are portable and can be plugged into the wall. In an electric heater, electricity is passed through a wire that resists the current, heating the wire. Electric heat warms up a room quickly and quietly, but it is very expensive.

Air conditioners (AC) are designed to move large amounts of heat out of the house. Window air conditioners can provide cooling in individual rooms, while central air conditioners cool entire homes. Air conditioning is very energy-intensive, so it's important to use it efficiently by using efficient temperature settings and keeping the system maintained. The best way to save when cooling is to use the AC as little as possible. Effective cooling strategies include:

- **Air Control**—Use convective heat transfer to cool by opening windows overnight if it cools off. In the morning, close windows before it heats up.
- **Sun Control**—Stop radiant heat transfer from the sun during the daytime, by closing shades. This can also be done by installing awnings or planting trees on the south side of the house.
- **Fans**—When opening windows on cool evenings, put a fan in the window to pull cool air through the house. Use a ceiling fan to circulate air in a room. Also, if you point a fan directly at you, it will keep you cooler and allow you to be more comfortable at higher temperatures.

Heat pumps and geothermal systems work very similar to air conditioning. The difference is that these units can reverse the direction of heat transfer in the winter to heat the home. That is, they can absorb thermal energy from outdoor air (or from the ground in a geothermal system) and bring it indoors. Heat pumps are the most efficient form of electric heating in moderate climates. When properly installed, a heat pump can deliver 1.5 to 3 times more heat energy to a home than the electrical energy it consumes.

## Residential Geothermal Exchange Units

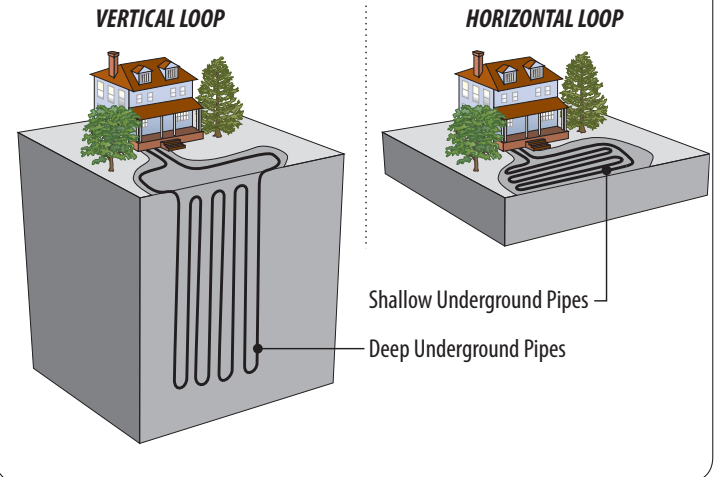

Geothermal heat pumps use the constant temperature of the earth as an exchange medium for heat. Although many parts of the country experience seasonal temperature extremes—from scorching heat in the summer to sub-zero cold in the winter—the ground a few feet below the earth's surface remains at a relatively constant temperature.

Depending on the latitude, ground temperatures range from 45°F (7°C) to 75°F (21°C). So, like a cave, the ground's temperature is warmer than the air above it during winter and cooler than the air above it in summer. Geothermal heat pumps take advantage of this by exchanging heat with the earth through a ground heat exchanger.

Thermostats are used to control the heating and cooling systems in a home. Most consumers set the temperature higher than recommended during heating seasons and lower than recommended during cooling seasons, wasting energy. A temperature setting of 68°F (20°C) during the day and 58-60°F (14-15°C) at night during heating seasons is comfortable if people dress warmly and use warm blankets. During cooling seasons, a temperature setting of 78°F (25°C) is comfortable if people dress appropriately and use fans.

Programmable thermostats automatically control the temperature of buildings for time of day and can save energy and money, when programmed correctly, by automatically adjusting the temperature for times of the day when no one is home or when people are sleeping. Adjusting the thermostat by just two degrees can decrease bills significantly and prevent hundreds of pounds of carbon dioxide from entering the atmosphere each year.

## Water Heating

Water heating is the second largest energy expense in most homes, accounting for 18 percent of energy use on average. Usually water is heated in a tank-type water heater that is fueled by natural gas or electricity. Heated water is used for showers, hand washing, dishwashing, and cleaning. The five main ways to reduce water heating bills are:

- Use less hot water
- Make sure there are no water leaks or drips
- Turn down the thermostat on the water heater
- Insulate water heaters and water pipes
- Choose an energy efficient water heater when yours needs replacing

The easiest way to cut the cost of heating water is to reduce the amount of hot water consumed. This can be done with little cost and minor changes in lifestyle. Water-saving faucet aerators (which diffuse the flow of water) can be installed in bathrooms and kitchens. Water-saving showerheads are also available. They limit the flow of water while providing adequate flow for washing.

Most water heater thermostats are set much higher than necessary. A setting of 120 degrees Fahrenheit provides hot water suitable for most uses. Decreasing the temperature by 10 degrees Fahrenheit can result in energy savings of \$12 to \$30 per year. Buying a high efficiency or tankless water heater can save \$40-\$140 per year. Instead of heating a large amount of water and keeping it hot in a tank, these appliances only heat the water as it is being used.

## Lighting

Legislation under the Energy Independence and Security Act put restrictions on light bulbs and increased the energy efficiency requirements for bulbs sold in the U.S. These changes began a phase-out of traditional incandescent bulbs. Consumers now have many more efficient choices of halogen incandescents, Compact fluorescent light bulbs (CFLs), and Light emitting diodes (LEDs). Their widespread use is helping to bring prices down on all types of energy efficient lighting.

However, many homes are still lit with traditional incandescent light bulbs. Only 10 percent of the energy consumed by an incandescent bulb produces light; the rest is given off as heat. This is because light is produced by sending electricity through a filament that resists the current. This causes the filament to heat up and then glow.

Energy saving halogen incandescent bulbs are more energy efficient than traditional incandescents. Inside a halogen bulb, the filament is encapsulated and surrounded by halogen gas, increasing bulb efficiency. Halogen incandescent bulbs are available in a wide range of shapes and colors at hardware and home improvement stores.

CFLs work on a much different principle and have become more common. A fluorescent light is a glass tube with a powdered phosphor coating on the inner surface. The tube is filled with a gas and contains a small amount of mercury.

Electrodes are at the ends of the tube. An electric current is passed from one electrode to the other, turning some of the mercury atoms into vapor that emits rays of ultraviolet (UV) light. When these invisible UV rays strike the phosphor coating, the phosphor atoms

## Storage Water Heater

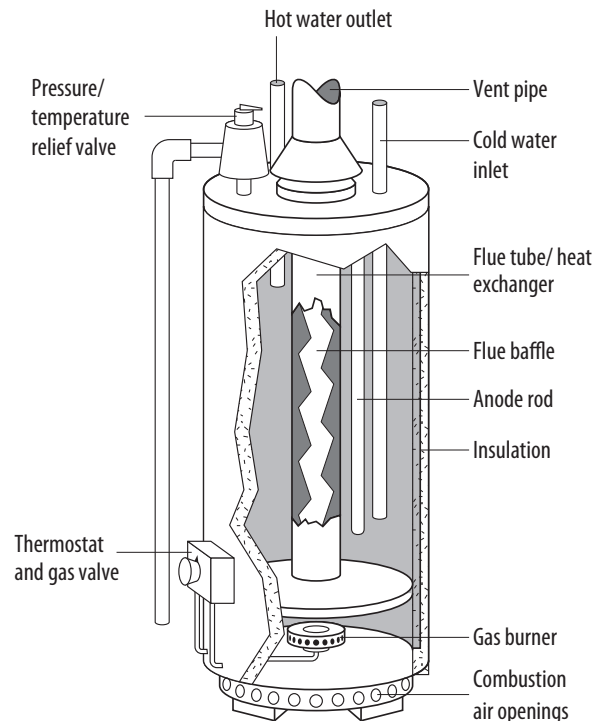

## Fluorescent Tube Lamp

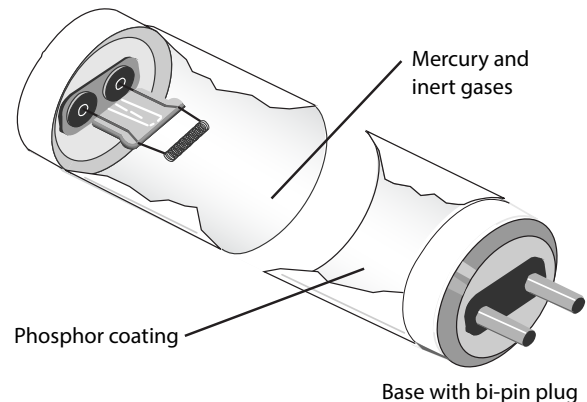

In fluorescent tubes, a very small amount of mercury mixes with inert gases to conduct the electric current. This allows the phosphor coating on the glass tube to emit light.

## Inside an LED

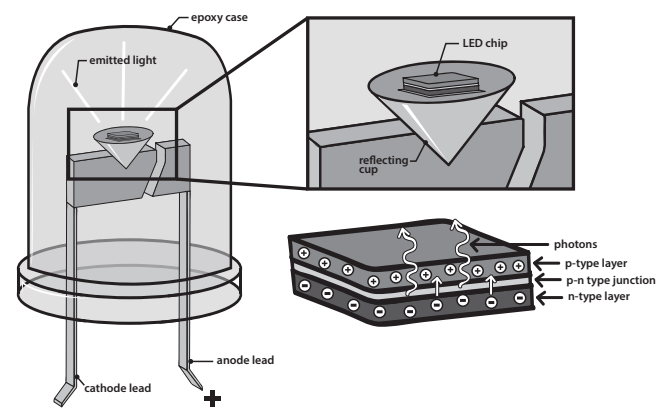

emit visible light. The conversion of one wavelength of radiant energy into another is called fluorescence. Fluorescent tubes produce very little heat and are much more energy efficient.

Although CFLs cost more to buy than traditional incandescents and energy saving halogens, they save money in the long run because they use only one-fourth the energy of incandescent bulbs and last 7-10 times longer. Installing CFLs will save you money in utility costs and reduce your carbon emissions.

LEDs, which have been commonly found in traffic lights, exit signs, car tail lights, and other applications, are now available as affordable options for home lighting. They contain no mercury and offer even more energy savings than CFLs. They last even longer than CFLs, they turn on instantly (some older CFLs take a moment to come on and some can take a few moments to warm up), and many of them can be used with a dimmer or even app-based programs. LED bulbs are comparable in price and sometimes cost even less than CFL bulbs, while providing even more energy savings.

Ways to save with lighting:

- Turn off lights when not in use
- Use day lighting whenever possible
- Use task lighting—instead of lighting the whole room provide light where it is needed
- Use CFLs or LED lighting instead of incandescent

### It's a System...

Using traditional incandescent light bulbs can increase energy use by your air conditioning since they produce so much heat.

## Appliances and Electrical Devices

Electrical devices account for around 29 percent of the average household's energy consumption, with refrigerators, televisions, clothes washers, and clothes dryers at the top of the consumption list. Home electronics and home office machines are also a significant and growing category of electricity users.

## Refrigerators

The easiest way to save energy with your refrigerator is through temperature settings. Most people keep their refrigerators colder than necessary. Setting the temperature in the "Smart Zone," 38-40 degrees, ensures that you use the minimum amount of energy to keep your food fresh. The freezer should be set to 5 degrees, while stand alone freezers should be set to 0 degrees for long term storage. Also, energy can be conserved by making sure the cold air inside the refrigerator stays there. Minimize the time that the refrigerator door is open by deciding what you want before opening the door. Also, check your refrigerator door seals to see if they are airtight. Test them by closing the door over a piece of paper so it is half in and half out. If you can pull the paper out easily, the latch may need adjustment or the seal may need replacing. If the appliance is more than 10 years old, you might consider buying a new unit.

## Laundry

Electric clothes dryers can often use 5,000 watts of electricity. That's the same as operating fifty 100 watt light bulbs. Drying only full loads, cleaning the lint filter after each load, and not over-drying your clothes are three effective ways to save. The dryer vent hose should also be cleaned periodically to ensure that lint is not building up and blocking the vent. Blockages in the vent hose cause the dryer to work harder, use more energy, and can also be a fire hazard. Newer dryers will sense when the laundry is dry and shut off automatically, saving energy.

Ninety-percent of the energy used by clothes washers is for heating the water. Using cold water detergents will allow you to wash in cold water, saving significantly on laundry costs. Another way to save is by only washing full loads. Newer, "horizontal axis" front-loading washing machines spin at a much higher rate, removing more water from clothes than regular, top-loading machines. This means clothes need less time in the dryer.

## Computers/Electronics

One of the easiest ways to save energy with computers, printers, and monitors is to simply turn them off when they are not in use, rather than leaving them in a "sleep" or "standby" mode. Turning computers off saves energy and will not harm the equipment.

## Washing Machine Payback Period

Spending a little bit more money on an energy efficient appliance could save you several hundred dollars over the lifetime of the product. The payback period could be shorter than you think!



	WASHER 1	WASHER 2	WASHER 3
Original Cost	\$379	\$497	\$999
Estimated Annual Electricity Use	427 kWh	160 kWh	102 kWh
Price of Electricity (per kWh)	\$0.12	\$0.12	\$0.12
Operating Cost per Year	\$51.24	\$19.20	\$12.24

Data: NEED Analysis of washing machine EnergyGuide labels

COST OVER THE LIFETIME OF THE MACHINE

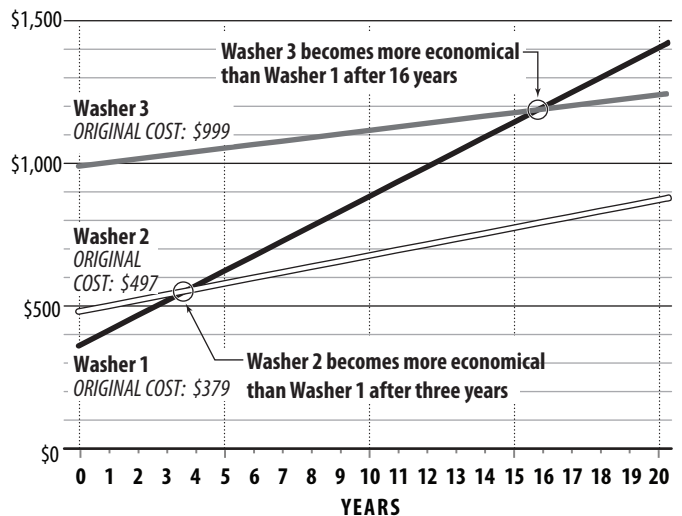

Check to see that the computer's power options are set to save energy during periods the computer is on, but not being used. Screensavers should be disabled, too, as they keep the monitor on instead of allowing it to go into a sleep mode.

Many electrical devices use electricity even when they are turned off. This type of electricity consumption is known as a phantom load, because it can easily go unnoticed. Phantom loads are also known as standby power or leaking electricity.

Phantom loads exist in many electronic or electrical devices found at home. Equipment with electronic clocks, timers, or remote controls, portable equipment, and office equipment with wall cubes (small box-shaped plugs that plug into AC outlets to power appliances) all have phantom loads. These devices can consume anywhere from 1-40 watts even when turned off. You can use a watt meter to see if devices are using power when they are turned off. These devices can be plugged into a power strip, which you can turn off when the devices are not in use.

### Shopping for New Appliances and Electronics

When you shop for a new appliance, consider both price tags. The first one covers the purchase price. The second price tag is the cost of operating the appliance. You'll pay the second price tag on your utility bill every month for as long as you own the appliance. An energy efficient appliance will often cost more, but will save money in energy costs. An energy efficient model is almost always a better deal.

When shopping for a new electrical device or appliance, look for the ENERGY STAR® label—your assurance that the product saves energy. ENERGY STAR® appliances have been identified by the U.S. Environmental Protection Agency and Department of Energy as the most energy efficient products in their classes.

Equipping our homes only with products with the ENERGY STAR® label, will reduce our energy bills, as well as greenhouse gas emissions by a significant amount. A list of appliances meeting energy efficient standards can be found on the ENERGY STAR® website at [www.energystar.gov](http://www.energystar.gov).

Another way to determine which appliance is more energy efficient is to compare energy usage using the bright yellow and black EnergyGuide labels found on most appliances, as required by the Federal Government. Although these labels do not say which appliance is the most efficient, they provide the estimated annual energy consumption and average operating cost of each appliance so you can compare them.

Ways to save with appliances and electronics:

- Turn off equipment and appliances when not in use
- Set refrigerator and freezer temperatures in the "Smart Zone"
- Wash and dry full loads of laundry
- Use a cold water clothes wash cycle
- Enable power management settings on computers/peripherals and disable screensavers
- Use power strips to eliminate "phantom loads"

## Electrical Devices



Television



Laptop



Game Console



DVD Player

These are common electrical devices that continue to draw power even when they are turned off. Cutting off power completely will save energy and money. Do this by unplugging the device or using a power strip.

## ENERGYGUIDE LABEL

U.S. Government Federal law prohibits removal of this label before consumer purchase.

# ENERGYGUIDE

Refrigerator-Freezer

- Automatic Defrost
- Top-mounted
- No Through-the Door Ice Service

BRAND B  
Model 1  
Capacity: 21.1 Cubic Feet

\$49

Estimated Yearly Energy Cost

\$40 \$65

Cost range not available

410 kWh

Estimated Yearly Electricity Use

\* Your cost will depend on your utility rates and use.

\* Cost range based only on models of similar capacity with Automatic Defrost, Top-mounted, and No Through-the Door Ice Service.

\* Estimated energy cost based on a national average electricity cost of 12 cents per kWh.

[ftc.gov/energy](http://ftc.gov/energy)

## High Performance or Green Buildings

High performance (HP) buildings are designed to provide occupants with superior indoor air quality, a healthy and productive environment with well-designed lighting and ventilation systems, while using minimal energy and water. Buildings can be constructed to high performance standards or existing buildings can be renovated to become HP buildings.

HP buildings always emphasize the quality of the building envelope. The envelope is sealed as much as possible to minimize the air exchange between indoors and outdoors and then insulated to create a uninterrupted blanket around the building. Ventilation systems are added to ensure a healthy level of air exchange with the outdoors while minimizing energy use. HP buildings will also be designed with the building site in mind. Strategies for using natural daylight for lighting and heating may be incorporated and rainwater may be collected for landscape use and even for flushing toilets. Non-toxic and natural materials are often used in the interior to minimize indoor air pollution and environmental impact. HVAC systems are smaller than in typical buildings since the building design minimizes the amount of heating and cooling necessary. Sometimes geothermal systems are used. Often, some way of generating electricity is incorporated as well, such as solar photovoltaic (PV) systems, or wind turbines. Some extremely efficient buildings actually produce as much or more energy than they consume and are referred to as “net zero” buildings.

To earn the ENERGY STAR® label, a home must meet strict guidelines for energy efficiency set by the U.S. Environmental Protection Agency. These homes include energy-saving features that typically make them up to 30 percent more efficient than typical new homes.

To date, more than 1.5 million ENERGY STAR® qualified homes have been built in the United States. Families living in these homes save about \$300 each year on their utility bills, compared to others, while reducing greenhouse gas emissions by 3,700 pounds per year. Some communities are now requiring that all new homes are built to ENERGY STAR® standards.

LEED, which stands for Leadership in Energy and Environmental Design, is a voluntary rating system that promotes the design and construction of high-performance green homes. LEED goes further than ENERGY STAR®, by setting requirements beyond energy and water use and indoor air quality. For instance, LEED ensures that construction waste is minimized and that environmentally-preferable products are used where possible. LEED ensures that great care went into the decisions on where the buildings would be located, taking advantage of local resources and infrastructure, and how the landscape features were designed. LEED also requires the builder to educate the homeowner or tenant on all of the green features of the home through a homeowner’s manual.

## Occupants

Having a building envelope, HVAC systems, electronics, appliances, and lighting that are well built and energy efficient will go a long way toward having a home system that works effectively and efficiently. However, how well the house functions as a system, even if it is ENERGY STAR® or LEED rated, is up to the occupants. Wise energy use and maintaining the parts of the home system will ensure that your home system is doing all it can to keep you comfortable, safe, and healthy.

### HIGH PERFORMANCE HOUSE



Simple tests can help you learn how your home uses energy. Whether you make upgrades to an existing home, or build a new home with energy efficient products, your home can be a well functioning system that provides shelter and is a healthy and comfortable living environment.



# What Does a Building Analyst Do?

Building analysts diagnose and treat problems with houses in much the same way that doctors work with their patients. They are trained to understand how heat, air, and moisture move through and affect the home and they use this understanding to improve the home's indoor environment and reduce its energy use. The building analysts' work also improves the environment by decreasing air pollution from home heating appliances and by decreasing the amount of electricity used by homes.

The building analyst (BA) might begin work on a house before ever seeing it. Looking at the utility bills for the home, the analyst learns how much energy is used in the home and how this use changes from month to month. This provides clues about what the analyst might look for. Take a look at the graphs below. They show the natural gas and electricity usage of a home in Upstate New York.

The natural gas usage increases in the winter, telling the BA that the house is heated by a gas furnace or boiler. Since there is still some usage in the summer, it is likely that the water heater runs on natural gas, as well. Electricity use goes up in the summer. Seeing this the BA will investigate the use of air conditioning at the home.

The BA's work at the house begins even before getting out of the vehicle. Just looking at the house from the street can provide a lot of information.

Looking at the pictures on the right, we see patches of the roof where the snow has melted. The BA will look in the attic by these locations to see if there are gaps in the insulation or if there are places where heated air from the house is leaking into the attic through gaps or cracks. You might be able to find some other clues to home performance problems in the photos.

## SNOW MELT



A building analyst can look at snow melt on a roof and have a good idea about whether or not an attic is well insulated and air sealed.

## MEASURING INSULATION



Image courtesy of the U.S. Department of Agriculture

## Sample Energy Usage Graphs

### Electricity Usage (kWh)

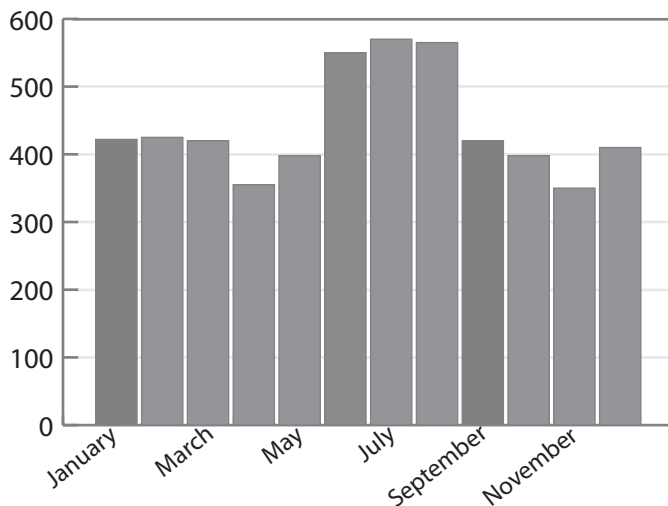

### Gas Usage (Therms)

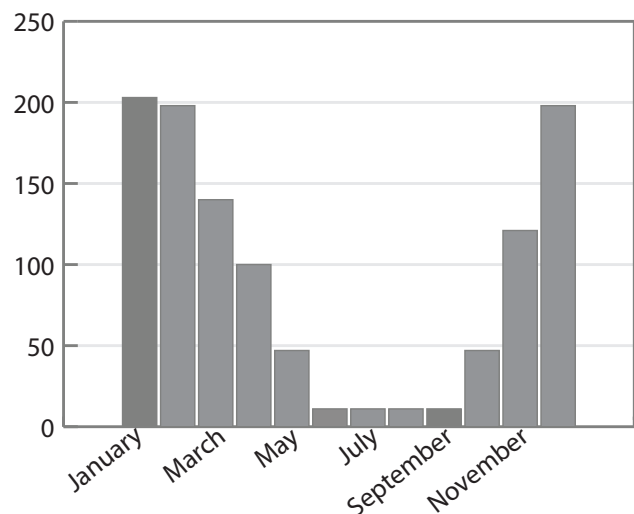

The BA investigates the outside of the home and measures the dimensions of the walls, windows, and other parts of the structure. If the measurements are known and the utility usage is known, it's possible for the analyst to determine how efficient the home is compared to others and determine the potential for energy savings. Next, the BA goes inside to check insulation levels in the attic, walls, and other locations. Electrical appliances and lighting are also evaluated to see if they are contributing to high utility bills.

The homeowner can provide valuable information to the BA, as well. By interviewing the homeowner, the BA will find out how the home is used and what remodeling might be done in the future. The homeowner can also let the BA know about areas of the house that are uncomfortable or drafty or where there are problems with moisture.

An important part of the BA's work is to make sure that the furnace or boiler and water heater are operating safely. If they burn a fuel such as natural gas, the BA tests them to make sure that their emissions are not getting into the home.

The blower door is a testing instrument the BA will use to measure the amount of air leakage in the home. It consists of a fan mounted in a frame that is inserted in an exterior doorway. Before turning on the fan, all doors and windows are closed and latched tightly, sealing up the home as much as possible. The fan is set up to blow air out of the home. This naturally pulls air into the house through any cracks in the building envelope and forces it out through the fan. A device called a manometer is used to measure the pressure difference between inside and outside, as well as the amount of air being pulled through the fan. With this data, the BA can calculate the leakiness of the home and determine how much energy can be saved by sealing up the building. After any sealing is done, the test will be run again to make sure that enough air will naturally circulate through the house to provide a healthy indoor environment.

Another tool the BA might use is an infrared (IR) camera. Instead of sensing light like most cameras, IR cameras detect heat coming from an object's surface. The analyst can use this information to determine areas that are not insulated or have significant air leakage.

Once all the data has been gathered, the BA will analyze it to determine the most effective work that can be done on the house. This can vary widely from house to house but might include insulation, air sealing, more efficient electrical appliances and lighting, or new heating or air conditioning systems. The BA has to balance the cost of the work against the money the homeowner will save on their future utility bills. To make a final selection of actions to be taken, the BA will use a computer program called a

## BLOWER DOOR TEST



building model, where the home's energy use is simulated. The BA can try out different equipment or actions in the model to see how they might affect the home's energy use. Once the actions are determined, the BA will provide a report to the homeowner describing the recommendations.

BAs use a variety of skills to diagnose home performance problems. Similar to a detective, they use observation skills and employ specialized equipment to gather data. Then they analyze the information they gathered using their math skills along with computer technology. At the end of the process, the BA has helped the homeowner lower his/her utility bills, while making the home a healthier and more comfortable place to live.



# House as a System Organizers

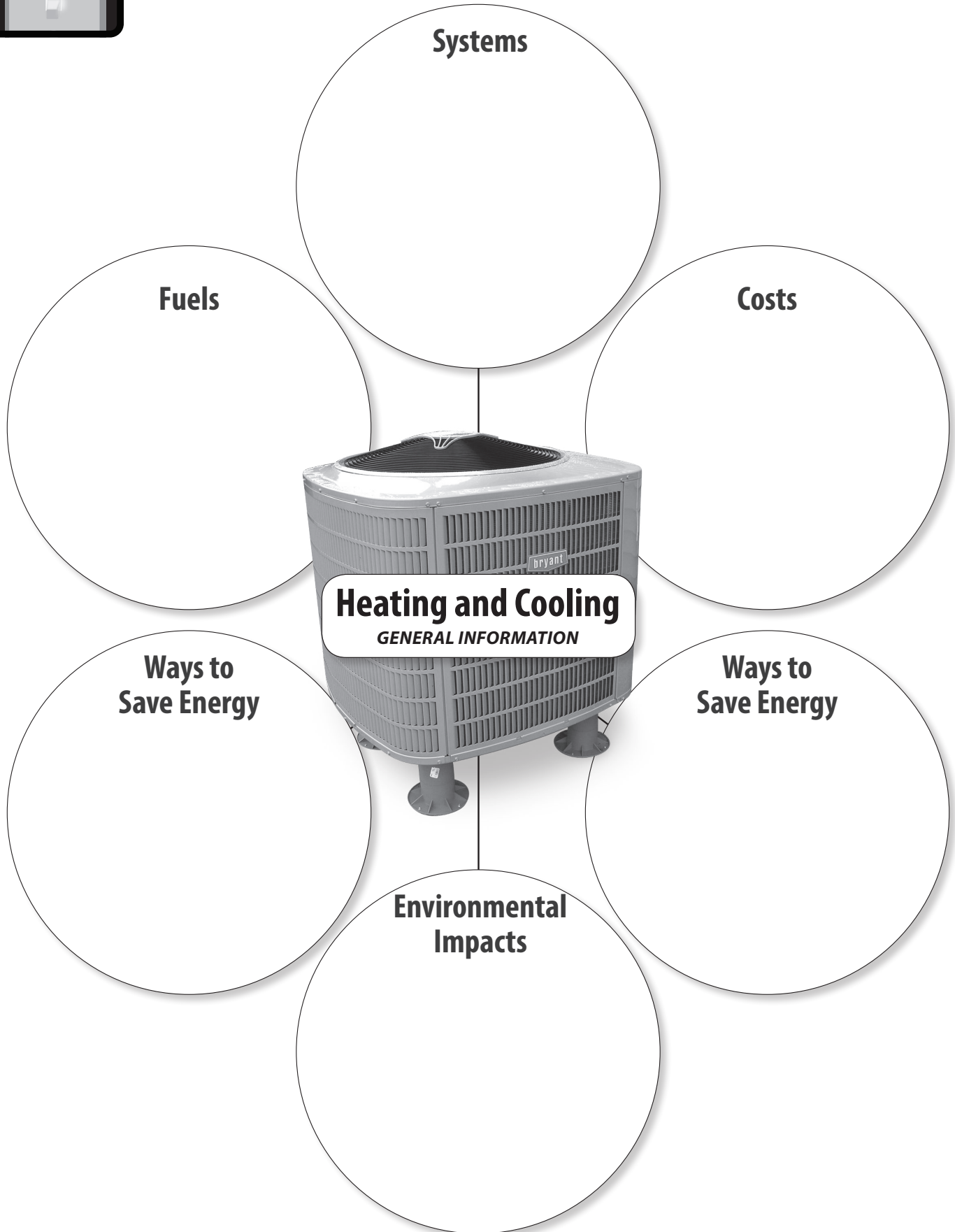



**ENERGY STAR®**

**Energy Users**

**EnergyGuide  
Labels**



**Appliances and  
Machines**

**Ways to Save Energy**



**Important Facts  
About Lighting**

A grey American Polaris water heater tank with a black base. The tank has a label on top that says "American POLARIS". The base has a control panel with a dial and some text. The water heater is centered in the image, surrounded by six empty circles.

## Water Heating Ways to Save Energy



# Conduction

## Insulation Section

---

1. List three common types of insulation:
2. Using the R-value chart on page 61, if you were going to insulate your attic, what would be the minimum recommended depth of cellulose you would install.
3. If you were to use fiberglass, what would be the minimum recommended thickness?
4. Which material would you need more of?
5. Explain why you would need more of one than the other.

### Insulation Data

Observation Times	Temperature			
	Blue Cavity	Red Cavity	Green Cavity	Yellow Cavity
Time: 0				
Time: 10 mins.				
Time: 20 mins.				
Time: 30 mins.				
Temperature Change				
Insulation Prediction				
Actual Insulation				

### \*\* Conclusion

Explain why it is important to insulate your home. Use data from your investigation to support your reasoning.



# Radiation

## Question

What is radiant transfer and how does it affect the heating and cooling of a building?

## Hypothesis:

---

---

---

---

## Materials

- IR thermometer

## Prediction

In the table below, list one or more components of the room (including walls, windows, doors, floor, ceiling, and any items in the room) that you believe will fall in the given temperature range.

Predicted Temperature Range	Component
40°-50°F	
50°-60°F	
60°-80°F	
80°-100°F	
100°-120°F	

## Procedure

Use the IR thermometer to check the actual temperature of each component from the table above.

## Data

Component	Actual Temperature

## **\*\* Conclusion**

---

1. Imagine that the space below is a map of the space you are in. Follow these steps:
  - a. Draw and label the components from the data table on page 53 onto the map below. Indicate the temperature of each component.
  - b. Draw an arrow from each component to at least one other component on the map, indicating the direction that heat is radiating.

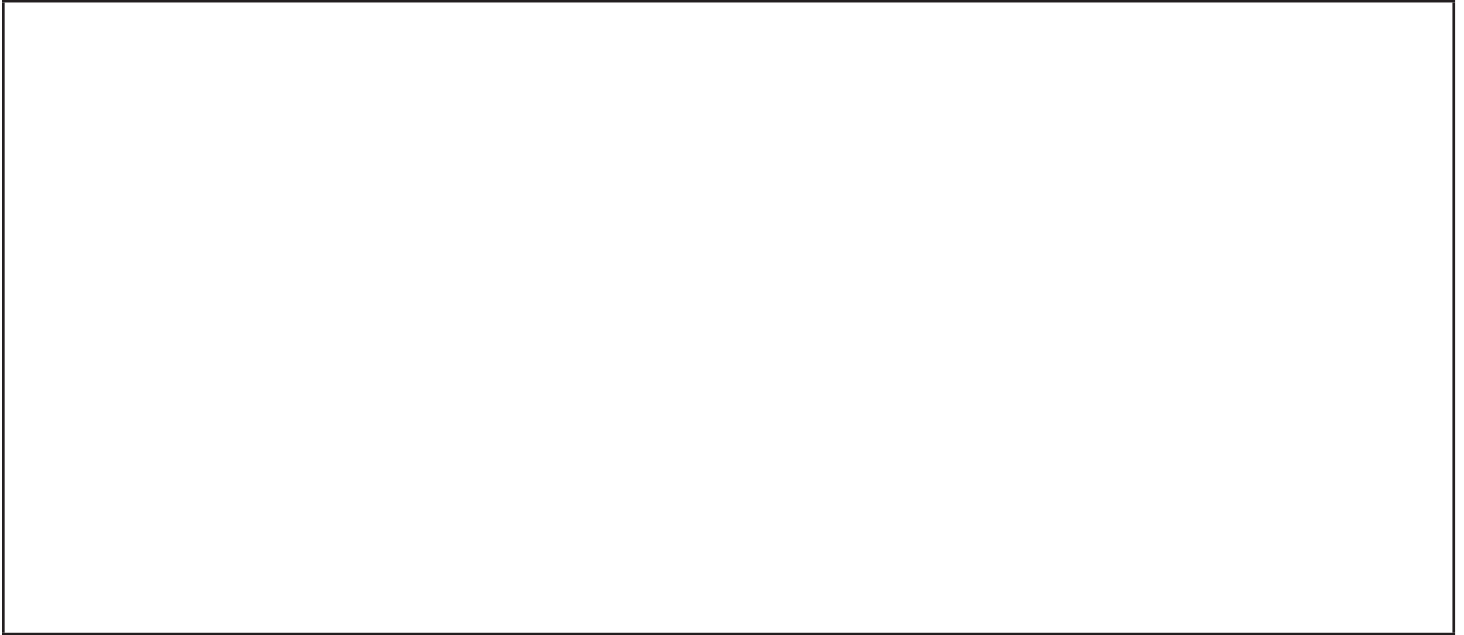

2. Based on your results, provide examples of how radiant heat transfer can affect the heating (or cooling) of your home or classroom.

3. Write a definition of radiant heat transfer.



# Home Airflow Simulation

## Question

How does air move in a household?

## Hypothesis:

## Materials

- Stackolator
- Smoke generator
- Roll of tape

## Procedure

1. On the following page, you will find four different scenarios where different combinations of holes are covered and uncovered. White holes should be left open. Black holes should be covered with tape (use the cap for the top of the Stackolator).
2. In each scenario, direct smoke to all open holes. If using an incense stick, hold the smoking tip up against the bottom lip of the hole being tested.
3. On the diagram, indicate the direction of air flow with arrows. Use different length arrows to indicate strength of air flow. Longer arrows equal stronger air flows. If ANY smoke is drawn into a hole, it should be recorded as a hole that is drawing in, even if some smoke stays outside of the tube.
4. Record additional observations about airflow movement as needed.

## Data and Observations

Record your data and observations on the next page.

## Conclusion

1. In general, where did you observe air entering the tube?
2. In general, where did you observe air exiting the tube?
3. At what locations did sealing make the greatest impact on reducing air flow through the Stackolator (refer to diagrams on the next page)? Why do you think this is? Use data from your observations to support your reasoning.
4. As a result of this experiment, in what area of a house do you think air sealing would have the greatest impact on energy use? Why?

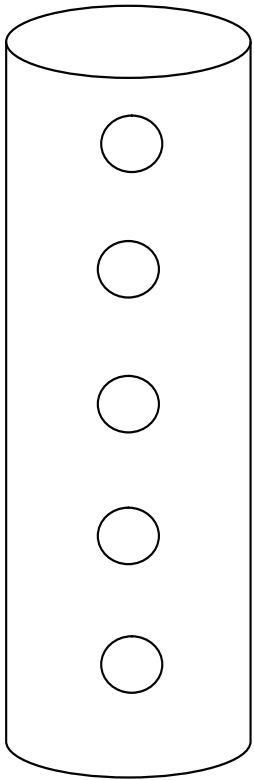

10 horizontal lines for data collection.

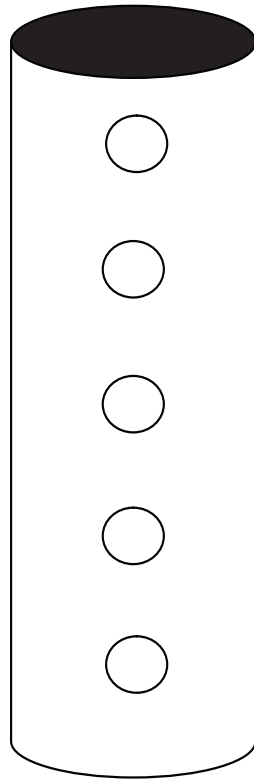

10 horizontal lines for data collection.

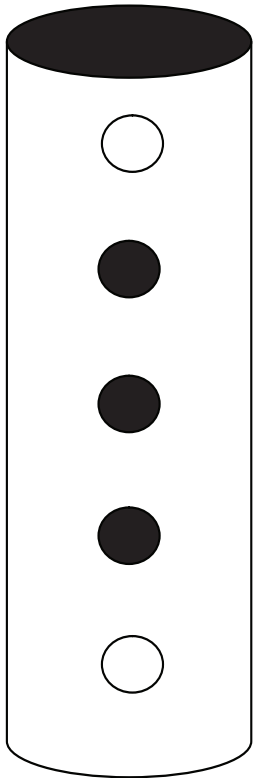

10 horizontal lines for data collection.

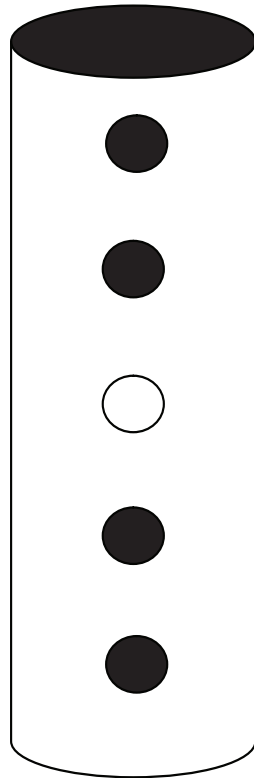

10 horizontal lines for data collection.





# Energy Systems and Sources

## Be an Energy Detective

Find out what kind of energy systems you have at home and the energy sources they use. Take a tour of your home with an adult. Look at the heating system, the air conditioning system, the stove and oven, the major appliances, the utility meters, and the water heater. Answer the questions below with your family's help.

1. What kind of heating system(s) do we have?

What source(s) of energy do we use to heat our home?

2. What kind of cooling system(s) do we have?

What source(s) of energy do we use to cool our home?

3. What cooking appliances do we have?

What source(s) of energy do we use to cook our food?

4. What kind of system(s) do we have to heat our water?

What source(s) of energy do we use to heat our water?

5. What source(s) of energy do we use to run our machines and appliances?

How many major appliances do we have?

\_\_\_\_\_ washer

\_\_\_\_\_ refrigerator

\_\_\_\_\_ freezer

\_\_\_\_\_ dryer

\_\_\_\_\_ dishwasher

\_\_\_\_\_ television

How many appliances do we have that are ENERGY STAR® qualified?



# Windows Investigation



## Question

How efficient are your classroom's windows?

## Hypothesis:

---

---

## Materials

- 1 Pencil
- 1 Piece of tape
- 1 Piece of tissue paper (1" x 12")

## Preparation

Tape a piece of tissue paper to the end of a pencil as shown in the picture.

## Procedure

1. Examine the window(s) in your classroom and record your observations.

OBSERVATION	SCHOOL WINDOWS
Direction windows face	
Single or double pane	
Special coating	
Blinds or shades	
Locking mechanism	
Caulking and weatherstripping	
Other observations	

2. Use the pencil with the tissue paper to check for air infiltration around the windows at school when they are closed. The tissue paper will flutter if any air is infiltrating. Record your observations.

---

---

---

---



# Investigating Windows and Air Infiltration at Home

## Question

How does air move into and out of your home?

## Hypothesis:

## Materials

- Pencil with tissue paper

## Procedure

1. Examine the windows in your home and record your observations.

Number of windows \_\_\_\_\_

Age of windows \_\_\_\_\_

\_\_\_\_\_ single pane - no storm windows

\_\_\_\_\_ single pane with plastic sheeting

\_\_\_\_\_ single pane with storm windows

\_\_\_\_\_ double pane

\_\_\_\_\_ double pane with gas fill

Special coating \_\_\_\_\_ yes \_\_\_\_\_ no

Heavy blinds or shades \_\_\_\_\_ yes \_\_\_\_\_ no

Awnings over south or west facing \_\_\_\_\_ yes \_\_\_\_\_ no

Locking mechanism \_\_\_\_\_ yes \_\_\_\_\_ no

Caulking and weatherstripping \_\_\_\_\_ yes \_\_\_\_\_ no

Other observations \_\_\_\_\_

2. Use the pencil with the tissue paper to check for air infiltration around the windows when they are closed. The tissue paper will flutter if any air is infiltrating. Record your observations.

---



---



---



---



---



# Investigating Home Insulation and Infiltration

## Question

Is your home well insulated and sealed?

## Hypothesis:

## Materials

▪ Ruler

## Procedure

- With the help of an adult, measure the amount of insulation in the attic of your home:  
     \_\_\_\_\_ < 5 inches      \_\_\_\_\_ 5-10 inches      \_\_\_\_\_ > 10 inches
- Open your outside doors and check the condition of the weatherstripping between the doors and the door-frame.  
     \_\_\_\_\_ none      \_\_\_\_\_ poor      \_\_\_\_\_ fair      \_\_\_\_\_ good
- Using the *Recommended R-Value Map*, determine in which Insulation Zone your home is located.  
     Zone \_\_\_\_\_
- According to the *Recommended R-Value Map*, what are the recommended R ratings in your Insulation Zone for the following:  
     Attic \_\_\_\_\_  
     Walls \_\_\_\_\_  
     Floors \_\_\_\_\_
- What are five areas of your home you can check for air leaks?  
     1. \_\_\_\_\_      4. \_\_\_\_\_  
     2. \_\_\_\_\_      5. \_\_\_\_\_  
     3. \_\_\_\_\_

## Insulation R-Values

TYPE OF INSULATION	R-VALUE (PER INCH)
Cellulose (high density or loose fill)	3.2 - 3.8
Fiberglass, batts	3.0
Foam board	7.0



**3.0**  
Fiberglass Batt



**3.7**  
Cellulose, Loose Fill

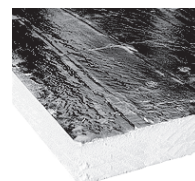

**7.0**  
Foam Board



# Recommended R-Value Map

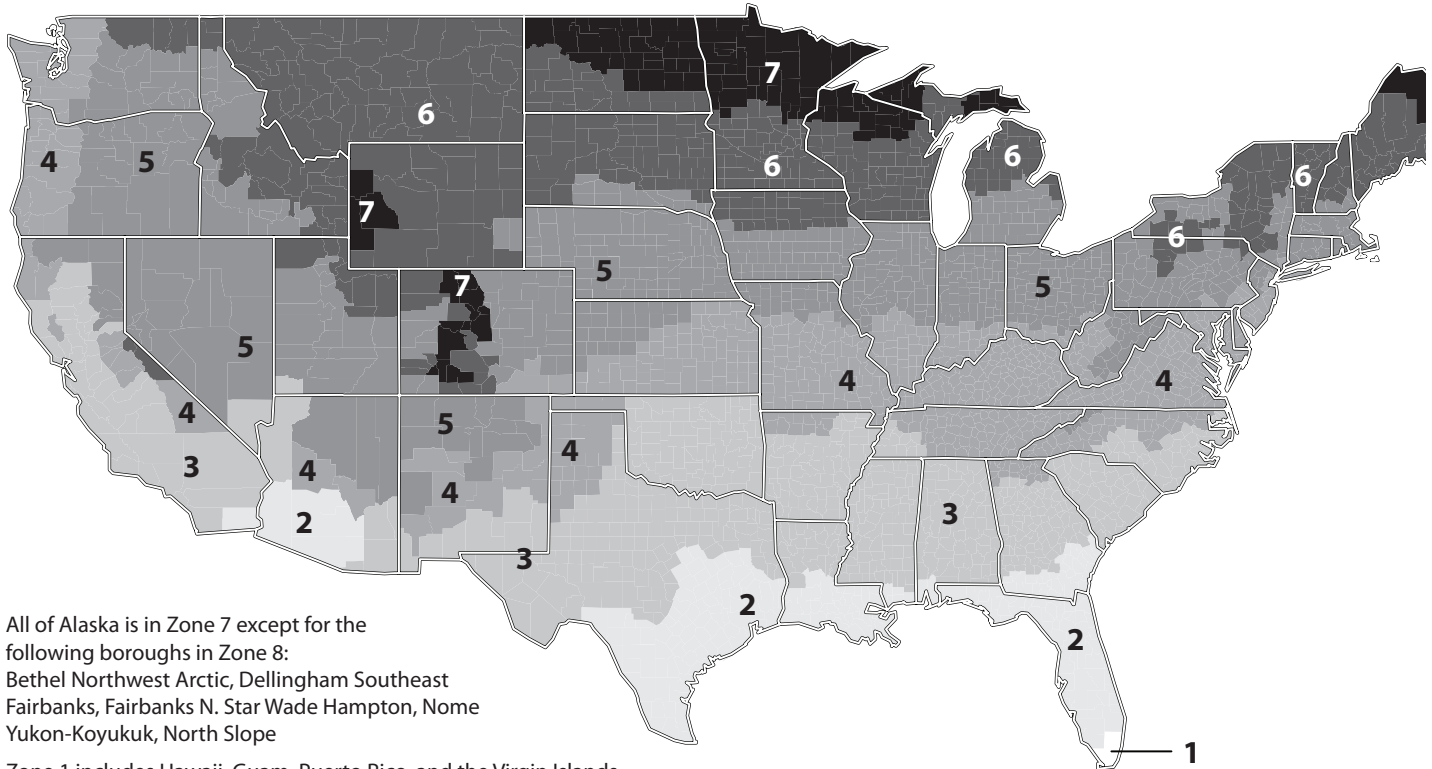

All of Alaska is in Zone 7 except for the following boroughs in Zone 8:  
Bethel Northwest Arctic, Dellingham Southeast  
Fairbanks, Fairbanks N. Star Wade Hampton, Nome  
Yukon-Koyukuk, North Slope

Zone 1 includes Hawaii, Guam, Puerto Rico, and the Virgin Islands.

## WALL INSULATION

ZONE	ATTIC	CATHEDRAL CEILING	CAVITY	INSULATION SHEATHING	FLOOR
1	R30 to R49	R22 to R38	R13 to R15	None	R13
2	R30 to R60	R22 to R38	R13 to R15	None	R13, R19 to R25
3	R30 to R60	R22 to R38	R13 to R15	R2.5 to R5	R25
4	R38 to R60	R30 to R38	R13 to R15	R2.5 to R6	R25 to R30
5	R38 to R60	R30 to R60	R13 to R21	R2.5 to R6	R25 to R30
6	R49 to R60	R30 to R60	R13 to R21	R5 to R6	R25 to R30
7	R49 to R60	R30 to R60	R13 to R21	R5 to R6	R25 to R30
8	R49 to R60	R30 to R60	R13 to R21	R5 to R6	R25 to R30

Data: U.S. Department of Energy



# Temperature Investigation

## Questions

Is the school's thermostat set correctly?

Is it wasting or saving energy?

## Hypothesis:

## Materials

- Digital humidity/temperature pen
- Probe thermometer

## Procedure

1. Upon viewing the school's heating and cooling system, find out the answers to the following questions:

Which system is in operation? \_\_\_\_\_

What energy source fuels the heating system? \_\_\_\_\_

What energy source fuels the cooling system? \_\_\_\_\_

2. Locate the thermostat in the classroom.

3. Record the temperature setting of the thermostat. \_\_\_\_\_

4. Using the thermometer, record the actual temperature of the classroom. \_\_\_\_\_

5. Using the humidity/temperature pen (hygrometer), record the relative humidity of the room. \_\_\_\_\_

6. Using the *Thermostat Temperature Guide* below, determine whether your classroom is saving or wasting energy and by how much.

\_\_\_\_\_.

## Thermostat Temperature Guide

### HEATING

**ENERGY SAVING**

**ENERGY WASTING**

-20%	-10%	0%	+10%	+20%	+30%	+40%	+50%	+	+	+	+	+	+	+	+	+	+
64°	66°	68°	70°	72°	74°	76°	78°	80°	82°								
										+30%	+20%	+10%	0	-10%	-20%		

**ENERGY WASTING**

**ENERGY SAVING**

### COOLING





# Reading EnergyGuide Labels

Big appliances—like refrigerators and dishwashers—use a lot of energy in homes, schools, and businesses. Some appliances cost more than others to buy. Some appliances use more energy than others. Usually, the more expensive models use less energy than the cheaper ones.

All appliances must have an EnergyGuide label that tells shoppers how much energy it uses. This way, people can compare the life cycle cost of the appliances, as well as the purchase price. The life cycle cost of an appliance is the purchase price plus the energy cost over the life of the appliance. An energy-saving refrigerator might cost more to buy, but it would use a lot less energy than a cheaper model.

The law requires EnergyGuide labels on all new refrigerators, freezers, water heaters, dishwashers, clothes washers, air conditioners, and furnaces. The EnergyGuide labels list the manufacturer, the model, the capacity, the features, the amount of energy the appliance will use a year, its comparison with similar models, and the estimated yearly energy cost.



**Clothes washer:** To the right is an EnergyGuide label from an average energy-using clothes washer.

U.S. Government Federal law prohibits removal of this label before consumer purchase.

# ENERGYGUIDE

Clothes Washer  
Capacity Class: Standard

LG Electronics  
Models WM2350H\*C

**Compare only to other labels with yellow numbers.**  
These appliances were tested according to the same U.S. Government requirements.

**Estimated Yearly Energy Cost**  
(when used with an electric water heater)

**\$12**

\$10 \$71

Cost range of similar models

**102 kWh**  
Estimated Yearly Electricity Use

**\$7**  
Estimated Yearly Energy Cost  
(when used with a natural gas water heater)

- ⓘ Your cost will depend on your utility rates and use.
- ⓘ Cost range based only on standard capacity models.
- ⓘ Estimated operating cost based on six wash loads a week and a national average electricity cost of 12 cents per kWh and natural gas cost of \$1.09 per therm.

[ftc.gov/energy](http://ftc.gov/energy)





# Comparing EnergyGuide Labels

AN EXAMPLE



MODEL 1: \$720



MODEL 2: \$799

Let's go shopping for a new refrigerator! We want to buy a refrigerator that will save us money and energy over the life of the appliance, not just with the purchase price. The EnergyGuide labels for the refrigerators are shown at the bottom of the page. We can calculate how much it will cost each year for six years.

MODEL 1	EXPENSES	COST TO DATE	MODEL 2	EXPENSES	COST TO DATE
Purchase Price	\$720	\$720	Purchase Price	\$799	\$799
Year One	\$64	$\$720 + \$64 = \$784$	Year One	\$49	$\$799 + \$49 = \$848$
Year Two	\$64	$\$784 + \$64 = \$848$	Year Two	\$49	$\$848 + \$49 = \$897$
Year Three	\$64	$\$848 + \$64 = \$912$	Year Three	\$49	$\$897 + \$49 = \$946$
Year Four	\$64	$\$912 + \$64 = \$976$	Year Four	\$49	$\$946 + \$49 = \$995$
Year Five	\$64	$\$976 + \$64 = \$1,040$	Year Five	\$49	$\$995 + \$49 = \$1,044$
Year Six	\$64	$\$1,040 + \$64 = \$1,104$	Year Six	\$49	$\$1,044 + \$49 = \$1,093$

Compare the Cost to Date figures in Year Four. The life cycle costs favored Model One before the end of Year Four. At year five they were almost exactly the same. After year 5, Model Two was a better bargain. Since most refrigerators last about 20 years, which one would you buy?

U.S. Government Federal law prohibits removal of this label before consumer purchase.

## ENERGYGUIDE

Refrigerator-Freezer  
 • Automatic Defrost  
 • Top-mounted  
 • No Through-the Door Ice Service

BRAND A  
Model 1  
Capacity: 21.1 Cubic Feet

**Compare ONLY to other labels with yellow numbers.**  
Labels with yellow numbers are based on the same test procedures.

Estimated Yearly Energy Cost

**\$64**

\$40 ————— \$65  
 Cost range not available

**530 kWh**  
Estimated Yearly Electricity Use

\* Your cost will depend on your utility rates and use.  
 \* Cost range based only on models of similar capacity with Automatic Defrost, Top-mounted, and No Through-the Door Ice Service.  
 \* Estimated energy cost based on a national average electricity cost of 12 cents per kWh.

ftc.gov/energy

U.S. Government Federal law prohibits removal of this label before consumer purchase.

## ENERGYGUIDE

Refrigerator-Freezer  
 • Automatic Defrost  
 • Top-mounted  
 • No Through-the Door Ice Service

BRAND B  
Model 1  
Capacity: 21.1 Cubic Feet

**Compare ONLY to other labels with yellow numbers.**  
Labels with yellow numbers are based on the same test procedures.

Estimated Yearly Energy Cost

**\$49**

\$40 ————— \$65  
 Cost range not available

**410 kWh**  
Estimated Yearly Electricity Use

\* Your cost will depend on your utility rates and use.  
 \* Cost range based only on models of similar capacity with Automatic Defrost, Top-mounted, and No Through-the Door Ice Service.  
 \* Estimated energy cost based on a national average electricity cost of 12 cents per kWh.

ftc.gov/energy

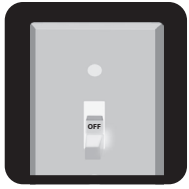

# Comparing Appliances

Your family needs to buy a new water heater. Water heaters usually last a long time—10 years or more—so you can save a lot of money on an energy efficient one. Use the chart below to figure out which water heater to buy, comparing the information on the EnergyGuide labels.

•How many years will it take before you begin to save money?

•How much money will you have saved after seven years?

**Water Heater 1: Purchase Price: \$375.00**

**Water Heater 2: Purchase Price: \$250.00**

WATER HEATER 1	EXPENSES	COST TO DATE	WATER HEATER 2	EXPENSES	COST TO DATE
Purchase Price			Purchase Price		
Year One			Year One		
Year Two			Year Two		
Year Three			Year Three		
Year Four			Year Four		
Year Five			Year Five		
Year Six			Year Six		
Year Seven			Year Seven		

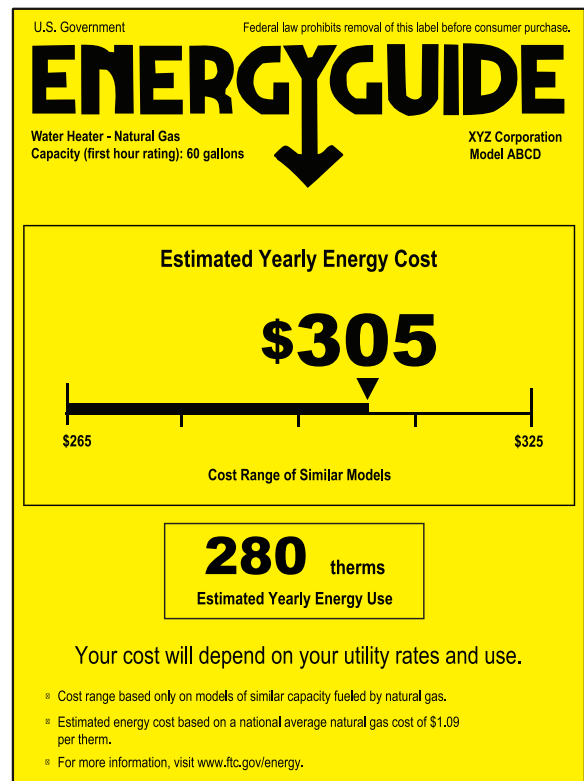
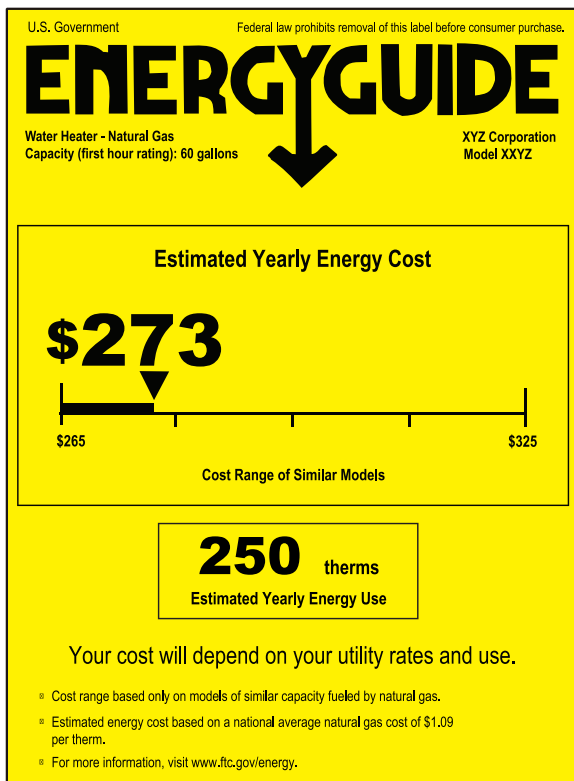



# Appliances and EnergyGuide Labels

## Question

Do you have energy efficient appliances?

## Materials

- Thermometer
- Dollar bill

## Procedure

1. With the help of an adult, test the seal on the door of your refrigerator. To do this, you will need a dollar bill. Close the door over the dollar bill so that it is half in and half out of the refrigerator. Grasp the end of the bill with both hands by the corners and pull slowly and steadily. Do not try to jerk it; it might tear.

- \_\_\_\_\_ comes out easily
- \_\_\_\_\_ comes out fairly easily
- \_\_\_\_\_ comes out with difficulty
- \_\_\_\_\_ does not move

2. Use a refrigerator thermometer to measure the temperature of your refrigerator and freezer and record in the chart below.

APPLIANCE	TEMPERATURE	SAFE ZONE (°F)
Refrigerator		37°-40°
Freezer Section		0°-5°
Separate Freezer		0° or Colder

3. Look around your house for large or small appliances that have ENERGY STAR® labels on them. Explain to your family that the ENERGY STAR® means the appliances meet strict energy efficiency standards. What ENERGY STAR® appliances did you find?



**CHANGE FOR THE  
BETTER WITH  
ENERGY STAR**

4. Take a trip with your family to a store that sells large appliances, such as refrigerators, and bring a piece of paper and writing utensil. Find two models of the same appliance such as refrigerators, dishwashers, or clothes washers. Record information from the EnergyGuide labels of the two models. Make sure that one appliance of each set is an energy efficient model. Make sure you also record the price of each appliance. You may also “shop” for these items online and download the labels for comparing. When you return home calculate the payback period of the energy efficient model.



# Kill A Watt® Monitor Instructions

## Kill A Watt® Monitor

The Kill A Watt® monitor allows users to measure and monitor the power consumption of any standard electrical device. You can obtain instantaneous readings of voltage (volts), current (amps), line frequency (Hz), and electric power being used (watts). You can also obtain the actual amount of power consumed in kilowatt-hours (kWh) by any electrical device over a period of time from 1 minute to 9,999 hours. One kilowatt equals 1,000 watts.

## Operating Instructions

1. Plug the Kill A Watt® monitor into any standard grounded outlet or extension cord.
2. Plug the electrical device or appliance to be tested into the AC Power Outlet Receptacle of the Kill A Watt® monitor.
3. The LCD displays all monitor readings. The unit will begin to accumulate data and powered duration time as soon as the power is applied.
4. Press the Volt button to display the voltage (volts) reading.
5. Press the Amp button to display the current (amps) reading.
6. The Watt and VA button is a toggle function key. Press the button once to display the Watt reading; press the button again to display the VA (volts x amps) reading. The Watt reading, not the VA reading, is the value used to calculate kWh consumption.
7. The Hz and PF button is a toggle function key. Press the button once to display the Frequency (Hz) reading; press the button again to display the power factor (PF) reading.
8. The KWH and Hour button is a toggle function key. Press the button once to display the cumulative energy consumption; press the button again to display the cumulative time elapsed since power was applied.

## What is Power Factor (PF)?

We often use the formula **Volts x Amps = Watts** to find the energy consumption of a device. Many AC devices, however, such as motors and magnetic ballasts, do not use all of the power provided to them. The power factor (PF) has a value equal to or less than one, and is used to account for this phenomenon. To determine the actual power consumed by a device, the following formula is used:

$$\text{Volts} \times \text{Amps} \times \text{PF} = \text{Watts Consumed}$$





# Kill A Watt® Investigation 1

Utility companies measure power consumption in kilowatt-hours (kWh). One 100-watt light bulb consumes 1 kWh (or 1,000 Wh) of electricity in ten hours. If the bulb is turned on an average of 80 hours a month, it consumes 8.0 kWh/month. To determine annual cost, multiply the kWh per month by the number of months used per year by the cost per kWh:

$$\text{kWh/month} \times \text{month/year} \times \text{cost/kWh} = \text{annual cost}$$

The average cost of a kWh of electricity for residential consumers is \$0.125 (8 kWh/month x 12 months/year x \$0.125/kWh = \$12.00/year). The average cost of a kWh of electricity for commercial consumers such as schools is \$0.10 (8 kWh/month x 9 months/year x \$0.10/kWh = \$7.20/year).

## Objective

Students will determine how much power selected electrical devices use per year.

## Procedure

1. Select several different electrical devices in the school and estimate the number of hours they are in use per week. Record your estimates in the table below.
2. Multiply the number of hours each device is used per week by the number of weeks it is used per year. For example, an item used year-round would require multiplying by 52, or the number of weeks in a year. Items only used during the school year or during specific seasons may be used less and would require multiplying by a different factor. A school year is typically around 40 weeks. Multiply and record this number in the table.
3. Use the Kill A Watt® monitor to measure the watts used by each device and record it in the table.
4. Divide the number of watts measured by 1,000 to convert watts into kilowatts.
5. Multiply the hours used per year by the number of kilowatts used. Multiply this number by the cost of a kWh to determine the annual cost of operating the device. Record your answer in the table.

## Data

Record your measurements and calculations in the table below.

ELECTRICAL DEVICE	HOURS PER WEEK	HOURS PER YEAR	WATTS MEASURED (W)	KILOWATTS (kW)	RATE (\$/kWh)	ANNUAL COST
Laptop	15	600	20	.02	\$0.10	\$1.20

## Conclusion

- Which electrical device uses the most power?
- Which electrical device uses the least power?
- Which electrical device costs the most to operate each year?
- Which electrical device costs the least to operate each year?



# Kill A Watt® Investigation 2

Some electrical devices appear to use more power when they are in active mode than when they are in idle mode. These devices include pencil sharpeners, copiers and printers, clock radios, and others. In addition, some devices such as fans appear to use more power at high speeds than at low speeds.

The Kill A Watt® monitor can be used to measure the power consumption of these electrical devices to determine the difference in consumption when these devices are operating in different modes.

## ★ Objective

Students will determine if electrical devices use different amounts of power when they are in different modes or operated at different speeds.

## ✓ Procedure

1. Select several electrical devices that might consume power at different rates while active and idle or while operating at different speeds. Estimate the average number of hours per week each device is in active use and the average number of hours per week the device is turned on, but idle, by interviewing users. Estimate the values with devices that can operate at different speeds. Record your estimates in the table below.
2. Multiply these values by the number of weeks it is in use per year. Multiply by 52 (total weeks in a year) or 40 (40-week school year) to calculate the average yearly amount of time each device is in use in each mode. Record these values in the table below.
3. Use the Kill A Watt™ monitor to measure the watts used in different modes of operation and record in the table below.
4. Divide the number of watts measured by 1,000 to convert watts into kilowatts.
5. Multiply the hours used per year by the number of kilowatts used. Multiply this number by the cost of a kWh to determine the annual cost of operating the device in each mode. Record your answer in the table.

## 📊 Data

Record your measurements and calculations in the table below.

ELECTRICAL DEVICE	HOURS PER WEEK	HOURS PER YEAR	WATTS MEASURED (W)	KILOWATTS (kW)	RATE (\$/kWh)	ANNUAL COST
<i>Copier (idle)</i>	36	1,440	20	.02	\$0.10	\$2.88
<i>Copier (active)</i>	4	160	1,200	1.2	\$0.10	\$19.20

## \*\* Conclusion

- Do some devices use more power when they are active than when they are idle?
- Do some devices use more power on high speed than on low speed?

*Note: Because some electrical devices cycle on and off without our control, the most accurate way to determine actual power consumption is to use the Kill A Watt® monitor to measure consumption over a 12–24 hour period. Refrigerators, for instance, cycle on and off in response to internal temperature sensors.*



# Facts of Light

Ten years ago, we used a lot of energy in the form of electricity to make light to be able to see. Thirty percent of the electricity schools used was for lighting, and homes used about 14 percent of their electricity consumption for lighting. That's because homes, schools, and other commercial buildings used a lot of incandescent lighting. These inefficient bulbs were perfected by Thomas Edison in 1879 and didn't change much for the next 125 or more years! These bulbs were surprisingly inefficient, converting up to 90 percent of the electricity they consumed into heat.

The Energy Independence and Security Act of 2007 changed the standards for the efficiency of light bulbs used most often. As of 2014, most general use bulbs must be 30 percent more efficient than traditional, inefficient incandescent bulbs. What do the new standards mean for consumers? The purpose of the new efficiency standards is to give people the same amount of light using less energy. Most incandescent light bulbs have since been phased out and are no longer available for sale. This has resulted in significant energy savings for homes and schools. Newer, efficient lighting now accounts for only 17 percent of the electricity used in schools, and eleven percent used in homes.

There are several lighting choices on the market that meet the new efficiency standards. Energy-saving incandescent, or halogen, bulbs are different than traditional, inefficient incandescent bulbs because they have a capsule around the filament (the wire inside the bulb) filled with halogen gas. This allows the bulbs to last three times longer and use 25 percent less energy.

Compact fluorescent light bulbs (CFLs) provide the same amount of light as incandescent bulbs, but use up to 75 percent less energy and last ten times longer. CFLs produce very little heat. Using CFLs can help cut lighting costs and reduce environmental impacts. Today's CFL bulbs fit almost any socket, produce a warm glow and, unlike earlier models, no longer flicker and dim. CFLs have a small amount of mercury inside and should always be recycled rather than thrown away. Many retailers recycle CFLs for free.

Light emitting diodes, better known as LEDs, are gaining in popularity. Once used mainly for exit signs and power on/off indicators, improved technology and lower prices are enabling LEDs to be used in place of incandescents and CFLs. LEDs are one of the most energy-efficient lighting choices available today. LEDs use 75 percent less energy than traditional incandescents, and have an average lifespan of at least 25,000 hours. The cost of LEDs has dropped in the last five years and may continue to drop. They use even less energy than CFLs, save more electricity, and produce fewer carbon dioxide emissions. The U.S. Department of Energy estimates that widespread adoption of LED lighting by 2027 would reduce lighting electricity demand by 33 percent. This would avoid construction of 40 new power plants.



	<b>INCANDESCENT BULB</b>	<b>HALOGEN</b>	<b>COMPACT FLUORESCENT (CFL)</b>	<b>LIGHT EMITTING DIODE (LED)</b>
Brightness	850 lumens	850 lumens	850 lumens	850 lumens
Life of Bulb	1,000 hours	3,000 hours	10,000 hours	25,000 hours
Energy Used	60 watts = 0.06 kW	43 watts = 0.043 kW	13 watts = 0.013 kW	12 watts = 0.012 kW
Price per Bulb	\$0.50	\$3.00	\$3.00	\$8.00



# Comparing Light Bulbs

The graphic on the previous page shows four light bulbs that produce the same amount of light. You might use bulbs like these as a bright overhead light. One bulb is an incandescent light bulb (IL), one is a halogen, one is a compact fluorescent light (CFL), and another is a light emitting diode (LED). Which one is the better bargain? Let's do the math and compare the four light bulbs using the commercial cost of electricity at \$0.10/kWh.

1. Determine how many bulbs you will need to produce 25,000 hours of light by dividing 25,000 by the number of hours each bulb produces light.
2. Multiply the number of bulbs you will need to produce 25,000 hours of light by the price of each bulb. The cost of each bulb has been given to you.
3. Multiply the wattage of the bulbs (using the kW number given) by 25,000 hours to determine kilowatt-hours (kWh) consumed.
4. Multiply the number of kilowatt-hours by the cost per kilowatt-hour to determine the cost of electricity to produce 25,000 hours of light.
5. Add the cost of the bulbs plus the cost of electricity to determine the life cycle cost for each bulb. Which one is the better bargain?
6. Compare the environmental impact of using each type of bulb. Multiply the total kWh consumption by the average amount of carbon dioxide produced by a power plant. This will give you the pounds of carbon dioxide produced over the life of each bulb. Which one has the least environmental impact?



All bulbs provide about 850 lumens of light.

COST OF BULB	INCANDESCENT BULB	HALOGEN	COMPACT FLUORESCENT (CFL)	LIGHT EMITTING DIODE (LED)
<b>Life of bulb (how long it will light)</b>	1,000 hours	3,000 hours	10,000 hours	25,000 hours
Number of bulbs to get 25,000 hours				
<b>x</b> Price per bulb	\$0.50	\$3.00	\$3.00	\$8.00
<b>=</b> Cost of bulbs for 25,000 hours of light				
COST OF ELECTRICITY	INCANDESCENT BULB	HALOGEN	COMPACT FLUORESCENT (CFL)	LIGHT EMITTING DIODE (LED)
Total Hours	25,000 hours	25,000 hours	25,000 hours	25,000 hours
<b>x</b> Wattage	60 watts = 0.060 kW	43 watts = 0.043 kW	13 watts = 0.013 kW	12 watts = 0.012 kW
<b>=</b> Total kWh consumption				
<b>x</b> Price of electricity per kWh	\$0.10	\$0.10	\$0.10	\$0.10
<b>=</b> Cost of Electricity				
LIFE CYCLE COST	INCANDESCENT BULB	HALOGEN	COMPACT FLUORESCENT (CFL)	LIGHT EMITTING DIODE (LED)
Cost of bulbs				
<b>+</b> Cost of electricity				
<b>=</b> Life cycle cost				
ENVIRONMENTAL IMPACT	INCANDESCENT BULB	HALOGEN	COMPACT FLUORESCENT (CFL)	LIGHT EMITTING DIODE (LED)
Total kWh consumption				
<b>x</b> Pounds (lbs) of carbon dioxide per kWh	1.23 lb/kWh	1.23 lb/kWh	1.23 lb/kWh	1.23 lb/kWh
<b>=</b> Pounds of carbon dioxide produced				





# Home Light Audit

1. How many total light bulbs are in your home? \_\_\_\_\_
2. How many compact fluorescent light bulbs are in your home?  
\_\_\_\_\_ No CFLs    \_\_\_\_\_ 1-3 CFLs  
\_\_\_\_\_ 4-6 CFLs    \_\_\_\_\_ > 6 CFLs
3. How many light emitting diodes (LED) are in your home?  
\_\_\_\_\_ No LEDs    \_\_\_\_\_ 1-2 LEDs  
\_\_\_\_\_ 3-4 LEDs    \_\_\_\_\_ > 4 LEDs
4. How much money did you and your family calculate you could save by replacing one incandescent bulb with a CFL?
5. If you replaced five incandescent bulbs with CFLs, how much money could you save?
6. When you replace an incandescent bulb with a CFL or LED, what measurement should you use to make sure you are getting a comparable light bulb?
7. If a nightlight uses only \$0.02 of electricity per year and lasts a lifetime, how much would you pay for electricity if you used the nightlight for 80 years?



# Home Energy Use Survey

## Be an Energy Detective

Complete this survey to begin to understand how much energy is used in your home. If you are not sure about a question, ask an adult for help.

1. Number of incandescent light bulbs in your home. \_\_\_\_\_
2. Number of compact fluorescent or LED light bulbs in your home. \_\_\_\_\_
3. Number of times your dishwasher is run per week. \_\_\_\_\_
4. How often the Energy Saver feature on the dishwasher is used.

0%                      25%                      50%                      75%                      100%

5. Number of loads of laundry washed per week. \_\_\_\_\_
6. Percentage of the laundry loads washed and rinsed in cold water.

0%                      25%                      50%                      75%                      100%

7. Total number of baths taken by all family members each week. \_\_\_\_\_
8. Total number of showers taken by all family members each week. \_\_\_\_\_
9. Average length of each shower. \_\_\_\_\_ minutes
10. Water heater temperature is set at 120°F or lower.    yes \_\_\_\_\_ no \_\_\_\_\_
11. Water heater is wrapped in an insulated blanket.    yes \_\_\_\_\_ no \_\_\_\_\_

12. Thermostat settings:

Cooling Season: Day \_\_\_\_\_°F                      Night \_\_\_\_\_°F

Heating Season: Day \_\_\_\_\_°F                      Night \_\_\_\_\_°F

13. Fans are used instead of air conditioning in warm weather.    yes \_\_\_\_\_ no \_\_\_\_\_
14. Window blinds are closed on hot, sunny days and open on cold, sunny days.    yes \_\_\_\_\_ no \_\_\_\_\_

15. How many times a day:

is a light left on in an unoccupied room? \_\_\_\_\_

is a TV, radio, computer, or video game left on with no one using it? \_\_\_\_\_

is the water allowed to run needlessly when brushing teeth or washing dishes? \_\_\_\_\_

is the stove or oven used to cook instead of the microwave or toaster oven? \_\_\_\_\_

is a door or window open when the heat or air conditioning is on? \_\_\_\_\_



# House Design Project

## Design Problem

---

You have been chosen to design and build a house that must meet the local building code. You must efficiently insulate and air seal the home in order to save the homeowners energy costs for years to come, while ensuring enough air flow to create a healthy indoor environment.

## Details

---

Your house will be tested to determine the highest temperature it can achieve in 15 minutes using two 15 watt incandescent light bulbs as a heat source. Your house may also be tested to determine whether an optimum amount of airflow is provided for both energy savings and occupant health. Some materials will be provided to you, but any additional materials you purchase must cost no more than \$10.

## Building Code

---

- The living space of your home must be between 32,500 and 49,500 cm<sup>3</sup>. The attic (see below) does not count in this space. The floor of the house must be at least 20 cm long (to accommodate the testing equipment).
- You must have at least one door to your house. The door must open and close. If you add a storm door, it must open. One door must be exactly 5 cm x 5 cm. (Verify the door size using the blower door apparatus before cutting.)
- You must have at least one window. Windows do not have to open but you must be able to see through them.
- You must have an attic in your home. This is not a living space and should not have a staircase to connect it. You must have a hatch in the ceiling of the house that leads to the attic that can be opened and closed.
- The ceiling must be at least 5 cm above the top of the door.
- Insulation on the floor and walls cannot exceed 3 cm in thickness.
- No insulation can be exposed. All insulation must be covered by a ceiling, wall, or floor. The walls and flooring must use a weak insulator such as poster board—no cardboard, foam core, etc.
- If your house is tested and does not have enough air flow, a ventilation inlet must be added. Add this by making a small, hinged door (approx. 3 cm x 3 cm) on one wall of the house. When re-testing, this door can be opened until the flap rests in the “green zone”. It can then be secured in this position.

## ✓ Procedure

---

### Design Problem

---

Ensure that everyone on your team understands the design problem.

### Research

---

In your notebook, record several research questions. These can be related to materials used, overall shape and design of the house, or other aspects of the project. Assign questions to each member of your team and research answers. You may want to design experiments to test out ideas, such as the insulating abilities of different materials.

### Planning

---

Plan your design by making sketches of the inside and outside of the house. Make drawings of important details such as how you will seal seams and gaps in your structure.

Specifications: Define the dimensions and shape of your house. Make a materials list and use the budget sheet provided to keep track of costs.

### Construction

---

Construct your house.

## Evaluate

- Test your house's performance following the instructions of your teacher. Test using the mini-blower door first. Then cut holes in the bottom of your house for temperature testing, using the provided template. After testing, evaluate your house's performance on the tests.
- Re-visit the design problem and make improvements to the design and construction of the house based on further research and planning. If you tested your house for airflow and it was too low, you must add a ventilation inlet (see building code on page 75).
- Re-test the house's performance.
- In your notebook, write an evaluation of the following:
  - The research process
  - Steps in the design process
  - The design of the house
  - The construction of the house
  - The cost of materials
  - How you would improve on the design/construction if you did this project again

## Building Center—Cost Sheet

Item	Amount
Packing tape	\$0.50/roll
Plastic film or plastic wrap	\$0.25/sheet
Aluminum foil (12" x 12")	\$1.00/meter
Bubble wrap	\$1.00/meter
Cotton batting	\$0.75/meter
Padded paper	\$0.50/meter
Caulking	\$0.01/cm
Poster board (24" x 6")	\$3.50/sheet
Weatherstripping	\$0.01/cm

## Conduction Test Results

1. Position the house over the heat source.
2. Insert the probe thermometer through the wall of the house 3 cm above the door.
3. Record the starting temperature.
4. Record the temperature every 5 minutes.
5. Determine the total temperature change.
6. After comparing the performance with other teams, evaluate your performance and determine if any improvements are needed.

Time								Total Temperature Change
House Temperature								



## House Test Template

---

1. Use this guide to cut holes in the bottom of your house for temperature testing.
2. Cut out the hole in the template.
3. Use the template twice to trace holes at any location on the bottom of the house. The template may not overlap when drawing.
4. Cut out holes in the house.

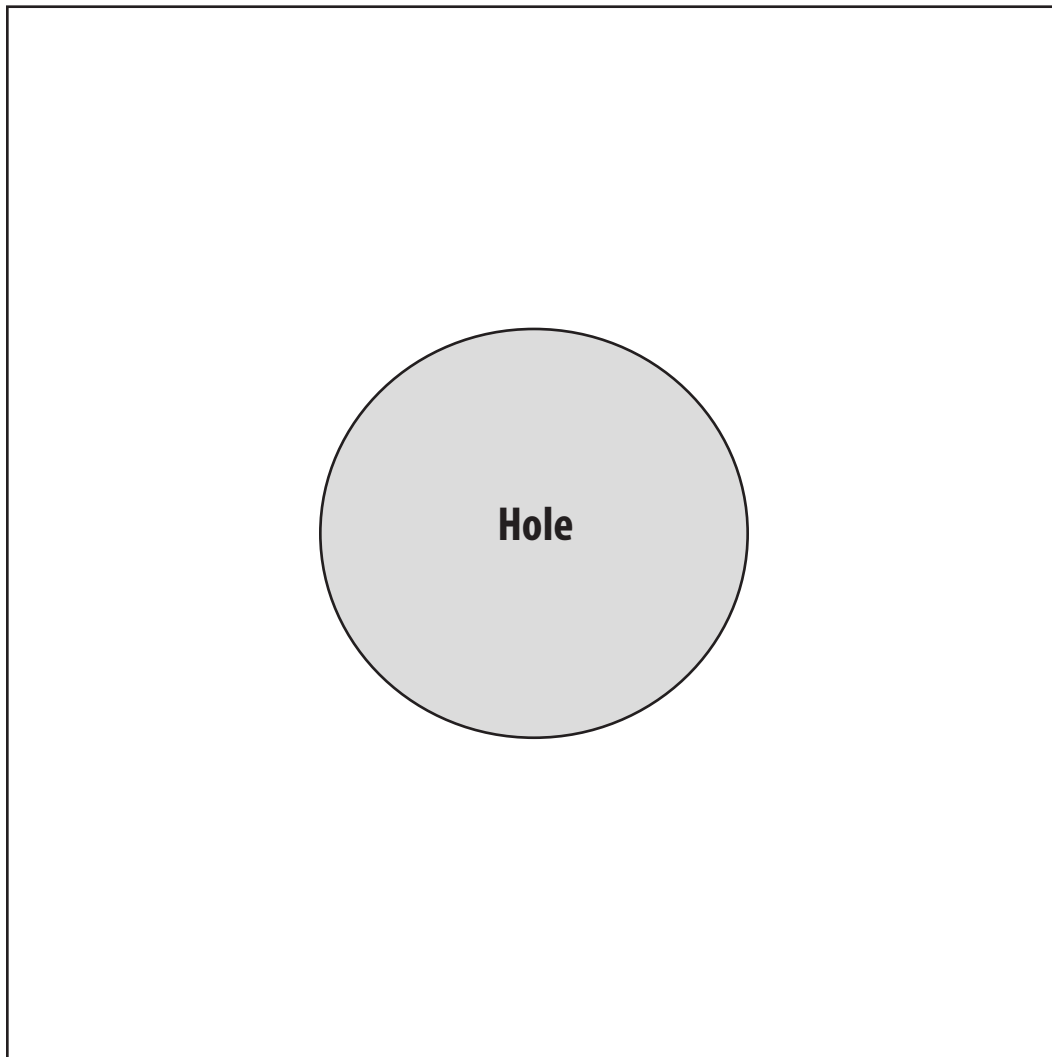



# Building Science Evaluation Form

State: \_\_\_\_\_ Grade Level: \_\_\_\_\_ Number of Students: \_\_\_\_\_

- |  |                              |                             |
|--|------------------------------|-----------------------------|
| 1. Did you conduct the entire unit?                              | <input type="checkbox"/> Yes | <input type="checkbox"/> No |
| 2. Were the instructions clear and easy to follow?               | <input type="checkbox"/> Yes | <input type="checkbox"/> No |
| 3. Did the activities meet your academic objectives?             | <input type="checkbox"/> Yes | <input type="checkbox"/> No |
| 4. Were the activities age appropriate?                          | <input type="checkbox"/> Yes | <input type="checkbox"/> No |
| 5. Were the allotted times sufficient to conduct the activities? | <input type="checkbox"/> Yes | <input type="checkbox"/> No |
| 6. Were the activities easy to use?                              | <input type="checkbox"/> Yes | <input type="checkbox"/> No |
| 7. Was the preparation required acceptable for the activities?   | <input type="checkbox"/> Yes | <input type="checkbox"/> No |
| 8. Were the students interested and motivated?                   | <input type="checkbox"/> Yes | <input type="checkbox"/> No |
| 9. Was the energy knowledge content age appropriate?             | <input type="checkbox"/> Yes | <input type="checkbox"/> No |
| 10. Would you teach this unit again?                             | <input type="checkbox"/> Yes | <input type="checkbox"/> No |

*Please explain any 'no' statement below.*

How would you rate the unit overall?  excellent  good  fair  poor

How would your students rate the unit overall?  excellent  good  fair  poor

What would make the unit more useful to you?

---

---

---

---

Other Comments:

---

---

---

---

Please fax or mail to: **The NEED Project**

8408 Kao Circle  
Manassas, VA 20110  
FAX: 1-800-847-1820



# National Sponsors and Partners

Air Equipment Company  
Albuquerque Public Schools  
American Electric Power  
Arizona Public Service  
Armstrong Energy Corporation  
Barnstable County, Massachusetts  
Robert L. Bayless, Producer, LLC  
BP America Inc.  
Bellefonte Area School District  
Blue Grass Energy  
Boys and Girls Club of Palm Beach County  
Cape Light Compact–Massachusetts  
Central Falls School District  
Chugach Electric Association, Inc.  
Citgo  
Clean Energy Collective  
Columbia Gas of Massachusetts  
ComEd  
ConEdison Solutions  
ConocoPhillips  
Constellation  
David Petroleum Corporation  
Desk and Derrick of Roswell, NM  
Direct Energy  
Dominion  
Dominion Nuclear  
Donors Choose  
Duke Energy  
East Kentucky Power  
Elba Liquefaction Company  
E.M.G. Oil Properties  
Encana Cares Foundation  
Energy Future Holdings  
Energy Market Authority – Singapore  
Escambia County Public School Foundation  
Eversource  
Exelon Foundation  
First Roswell Company  
Foundation for Environmental Education  
FPL  
The Franklin Institute  
Government of Thailand–Energy Ministry  
Green Power EMC  
Guilford County Schools – North Carolina  
Gulf Power  
Gerald Harrington, Geologist  
Harvard Petroleum  
Hawaii Energy  
Houston Museum of Natural Science  
Idaho National Laboratory  
Illinois Clean Energy Community Foundation  
Independent Petroleum Association of New Mexico  
James Madison University  
Kentucky Department of Energy Development and Independence  
Kentucky Power – An AEP Company  
Kentucky Utilities Company  
Kinder Morgan  
Leidos  
Linn County Rural Electric Cooperative  
Llano Land and Exploration  
Louisville Gas and Electric Company  
Massachusetts Division of Energy Resources  
Mississippi Development Authority–Energy Division  
Mojave Environmental Education Consortium  
Mojave Unified School District  
Montana Energy Education Council  
The Mountain Institute  
National Fuel  
National Grid  
National Hydropower Association  
National Ocean Industries Association  
National Renewable Energy Laboratory  
New Mexico Oil Corporation  
New Mexico Landman’s Association  
NextEra Energy Resources  
NEXTracker  
Nicor Gas  
Nisource Charitable Foundation  
Noble Energy  
Nolin Rural Electric Cooperative  
Northern Rivers Family Services  
North Carolina Department of Environmental Quality  
North Shore Gas  
NRG Energy, Inc.  
NRG Battle of the Regions Donors  
Offshore Technology Conference  
Ohio Energy Project  
Opterra Energy  
Pacific Gas and Electric Company  
PECO  
Pecos Valley Energy Committee  
Peoples Gas  
Petroleum Equipment and Services Association  
Phillips 66  
PNM  
Providence Public Schools  
Read & Stevens, Inc.  
Renewable Energy Alaska Project  
Rhode Island Office of Energy Resources  
Robert Armstrong  
Roswell Geological Society  
Salt River Project  
Salt River Rural Electric Cooperative  
Saudi Aramco  
Schlumberger  
C.T. Seaver Trust  
Shell  
Shell Chemicals  
Sigora Solar  
Society of Petroleum Engineers  
Society of Petroleum Engineers – Middle East, North Africa and South Asia  
Solar City  
David Sorenson  
Tennessee Department of Economic and Community Development–Energy Division  
Tesoro Foundation  
Tri-State Generation and Transmission  
TXU Energy  
United Way of Greater Philadelphia and Southern New Jersey  
University of North Carolina  
University of Tennessee  
U.S. Department of Energy  
U.S. Department of Energy–Office of Energy Efficiency and Renewable Energy  
U.S. Department of Energy–Wind for Schools  
U.S. Energy Information Administration  
Yates Petroleum Corporation